

Features and Benefits

Absolute 3D Position Sensor
Simple & Robust Magnetic Design
Triaxis™ Hall Technology
Programmable Linear Transfer Characteristics (Alpha, Beta)
Selectable Analog (Ratiometric), PWM, Serial Protocol
12 bit Angular Resolution - 10 bit Angular Thermal Accuracy
40 bit ID Number
Single Die – SO8 Package RoHS Compliant
Dual Die (Full Redundant) – TSSOP16 Package RoHS Compliant



Applications

| | |
|------------------------------|----------|
| 3D Position Sensor | Joystick |
| 4-Way Scroll Key | Joypad |
| Man Machine Interface Device | |

Ordering Information¹

| Part No. | Temperature Suffix | Package Code | Option code |
|----------|-----------------------|---------------|-------------|
| MLX90333 | K (– 40°C to + 125°C) | DC [SOIC-8] | - |
| MLX90333 | L (– 40°C to + 150°C) | DC [SOIC-8] | - |
| MLX90333 | K (– 40°C to + 125°C) | GO [TSSOP-16] | - |
| MLX90333 | L (– 40°C to + 150°C) | GO [TSSOP-16] | - |

¹ Example: MLX90333KDC

1. Functional Diagram

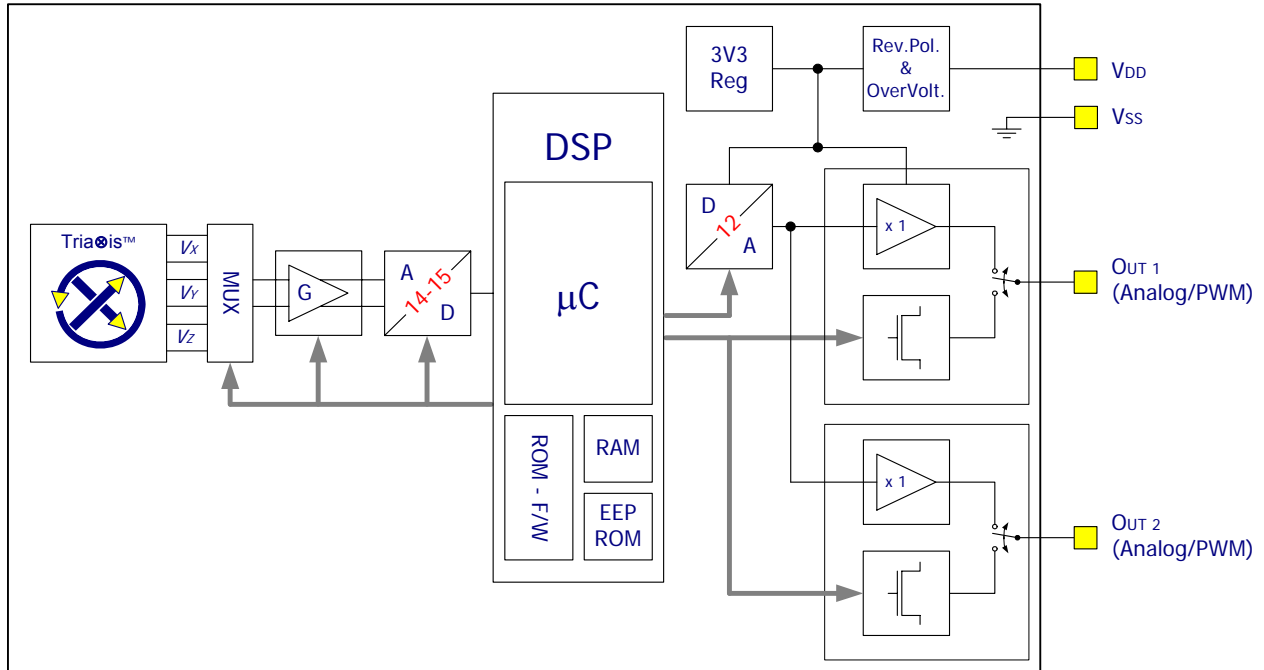

Figure 1 - Block Diagram (Analog & PWM)

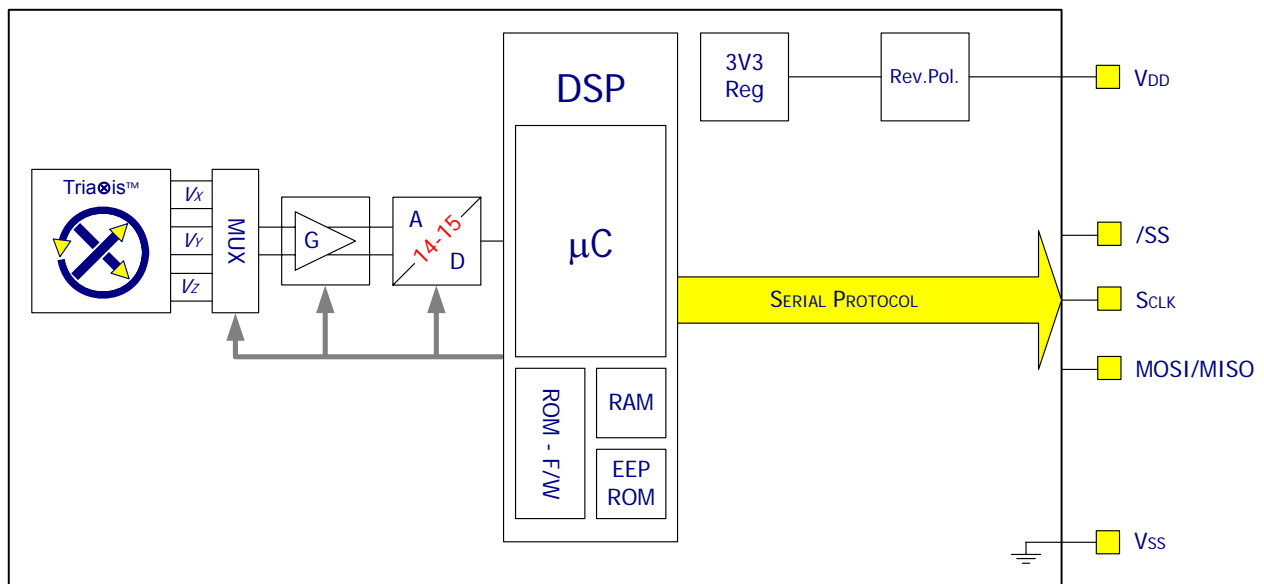

Figure 2 - Block Diagram (Serial Protocol)

2. Description

The MLX90333 is a monolithic sensor IC featuring the Tria \otimes is™ Hall technology. Conventional planar Hall technology is only sensitive to the flux density applied orthogonally to the IC surface. The Tria \otimes is™ Hall sensor is also sensitive to the flux density applied parallel to the IC surface. This is obtained through an Integrated Magneto-Concentrator (IMC®) which is deposited on the CMOS die (as an additional back-end step).

The MLX90333 is sensitive to the 3 components of the flux density applied to the IC (B_x , B_y and B_z). This allows the MLX90333 to sense any magnet moving in its surrounding and it enables the design of novel generation of non-contacting joystick position sensors which are often required for both automotive and industrial applications (e.g. man-machine interface).

Furthermore, the capability of measuring B_x , B_y and B_z allows the MLX90333 to be considered as universal non-contacting position sensor i.e. not limited to joystick applications. For instance, a linear travel can be sensed with the MLX90333 once included in a specific magnetic design.

In combination with the appropriate signal processing, the magnetic flux density of a small magnet (axial magnetization) moving above the IC can be measured in a non-contacting way (Figure 3). The two (2) angular information are computed from the three (3) vector components of the flux density (i.e. B_x , B_y and B_z). MLX90333 reports two (2) linear output signals. The output formats are selectable between Analog, PWM and Serial Protocol.

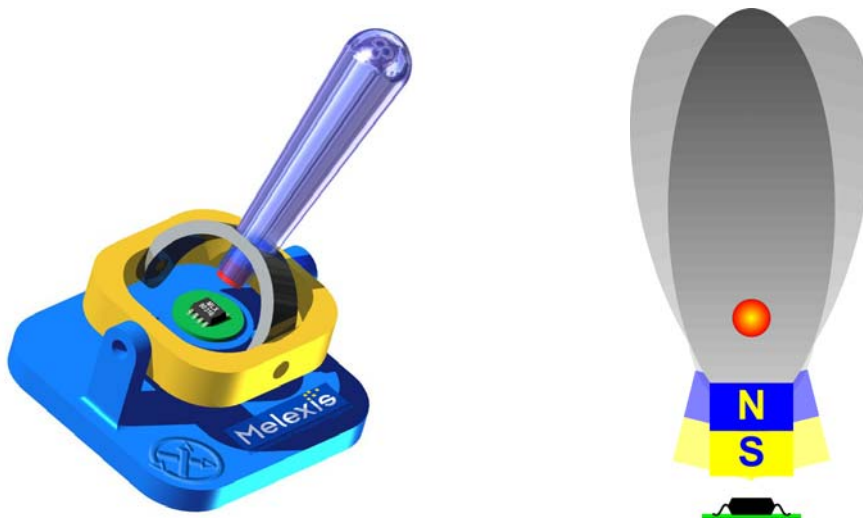

Figure 3 - Typical application of MLX90333

TABLE of CONTENTS

| | |
|--|-----------|
| FEATURES AND BENEFITS | 1 |
| APPLICATIONS..... | 1 |
| ORDERING INFORMATION..... | 1 |
| 1. FUNCTIONAL DIAGRAM..... | 2 |
| 2. DESCRIPTION..... | 3 |
| 3. GLOSSARY OF TERMS – ABBREVIATIONS – ACRONYMS | 6 |
| 4. PINOUT | 6 |
| 5. ABSOLUTE MAXIMUM RATINGS | 7 |
| 6. DETAILED DESCRIPTION..... | 7 |
| 7. MLX90333 ELECTRICAL SPECIFICATION..... | 13 |
| 8. MLX90333 ISOLATION SPECIFICATION | 15 |
| 9. MLX90333 TIMING SPECIFICATION | 15 |
| 10. MLX90333 ACCURACY SPECIFICATION | 16 |
| 11. MLX90333 MAGNETIC SPECIFICATION | 17 |
| 12. MLX90333 CPU & MEMORY SPECIFICATION | 17 |
| 13. MLX90333 END-USER PROGRAMMABLE ITEMS..... | 18 |
| 14. DESCRIPTION OF END-USER PROGRAMMABLE ITEMS..... | 19 |
| 14.1. OUTPUT CONFIGURATION | 19 |
| 14.2. OUTPUT MODE..... | 19 |
| 14.2.1. <i>Analog Output Mode</i> | 19 |
| 14.2.2. <i>PWM Output Mode</i> | 19 |
| 14.2.3. <i>Serial Protocol Output Mode</i> | 20 |
| 14.3. OUTPUT TRANSFER CHARACTERISTIC..... | 20 |
| 14.3.1. <i>The Polarity and Modulo Parameters</i> | 21 |
| 14.3.2. <i>Alpha/Beta Discontinuity Point (or Zero Degree Point)</i> | 22 |
| 14.3.3. <i>LNR Parameters</i> | 22 |
| 14.3.4. <i>CLAMPING Parameters</i> | 23 |
| 14.3.5. <i>DEADZONE Parameter</i> | 23 |
| 14.4. IDENTIFICATION | 24 |
| 14.5. SENSOR FRONT-END | 24 |
| 14.5.1. <i>HIGHSPEED Parameter</i> | 24 |
| 14.5.2. <i>GAINMIN and GAINMAX Parameters</i> | 24 |
| 14.5.3. <i>FIELDTHRES_MIN and FIELDTHRES_MAX Parameters</i> | 24 |
| 14.6. FILTER | 25 |
| 14.6.1. <i>Hysteresis Filter</i> | 25 |
| 14.6.2. <i>FIR Filters</i> | 25 |
| 14.6.3. <i>IIR Filters</i> | 26 |
| 14.7. PROGRAMMABLE DIAGNOSTIC SETTINGS | 28 |

| | | |
|------------|--|-----------|
| 14.7.1. | <i>RESONFAULT</i> Parameter | 28 |
| 14.7.2. | <i>EEHAMHOLE</i> Parameter | 28 |
| 14.8. | LOCK | 28 |
| 14.8.1. | <i>MLXLOCK</i> Parameter | 28 |
| 14.8.2. | <i>LOCK</i> Parameter | 28 |
| 15. | MLX90333 SELF DIAGNOSTIC | 29 |
| 16. | SERIAL PROTOCOL | 31 |
| 16.1. | INTRODUCTION | 31 |
| 16.2. | SERIAL PROTOCOL MODE | 31 |
| 16.3. | MOSI (MASTER OUT SLAVE IN) | 31 |
| 16.4. | MISO (MASTER IN SLAVE OUT) | 31 |
| 16.5. | /SS (SLAVE SELECT) | 31 |
| 16.6. | MASTER START-UP | 31 |
| 16.7. | SLAVE START-UP | 31 |
| 16.8. | TIMING | 32 |
| 16.9. | SLAVE RESET | 33 |
| 16.10. | FRAME LAYER | 33 |
| 16.10.1. | <i>Frame Type Selection</i> | 33 |
| 16.10.2. | <i>Data Frame Structure</i> | 33 |
| 16.10.3. | <i>Timing</i> | 33 |
| 16.10.4. | <i>Data Structure</i> | 34 |
| 16.10.5. | <i>Angle Calculation</i> | 34 |
| 16.10.6. | <i>Error Handling</i> | 34 |
| 17. | RECOMMENDED APPLICATION DIAGRAMS | 35 |
| 17.1. | ANALOG OUTPUT WIRING WITH THE MLX90333 IN SOIC PACKAGE | 35 |
| 17.2. | PWM LOW SIDE OUTPUT WIRING | 35 |
| 17.3. | ANALOG OUTPUT WIRING WITH THE MLX90333 IN TSSOP PACKAGE | 36 |
| 17.4. | SERIAL PROTOCOL | 36 |
| 18. | STANDARD INFORMATION REGARDING MANUFACTURABILITY OF MELEXIS PRODUCTS WITH DIFFERENT SOLDERING PROCESSES | 38 |
| 19. | ESD PRECAUTIONS | 38 |
| 20. | PACKAGE INFORMATION | 39 |
| 20.1. | SOIC8 - PACKAGE DIMENSIONS | 39 |
| 20.2. | SOIC8 - PINOUT AND MARKING | 39 |
| 20.3. | SOIC8 - IMC POSITIONNING | 40 |
| 20.4. | TSSOP16 - PACKAGE DIMENSIONS | 41 |
| 20.5. | TSSOP16 - PINOUT AND MARKING | 42 |
| 20.6. | TSSOP16 - IMC POSITIONNING | 42 |
| 21. | DISCLAIMER | 43 |

3. Glossary of Terms – Abbreviations – Acronyms

- Gauss (G), Tesla (T): Units for the magnetic flux density – 1 mT = 10 G
- TC: **Temperature Coefficient** (in ppm/Deg.C.)
- NC: **Not Connected**
- PWM: **Pulse Width Modulation**
- %DC: **Duty Cycle** of the output signal i.e. $T_{ON} / (T_{ON} + T_{OFF})$
- ADC: **Analog-to-Digital Converter**
- DAC: **Digital-to-Analog Converter**
- LSB: **Least Significant Bit**
- MSB: **Most Significant Bit**
- DNL: **Differential Non-Linearity**
- INL: **Integral Non-Linearity**
- RISC: **Reduced Instruction Set Computer**
- ASP: **Analog Signal Processing**
- DSP: **Digital Signal Processing**
- ATAN: trigonometric function: arctangent (or inverse tangent)
- IMC: **Integrated Magneto-Concentrator (IMC®)**
- CoRDIC: **Coordinate Rotation Digital Computer** (i.e. iterative rectangular-to-polar transform)
- EMC: **Electro-Magnetic Compatibility**

4. Pinout²

| Pin # | SOIC-8 | | TSSOP-16 | |
|-------|--------------|-----------------|---|---|
| | Analog / PWM | Serial Protocol | Analog / PWM | Serial Protocol |
| 1 | VDD | VDD | VDIG ₁ | VDIG ₁ |
| 2 | Test 0 | Test 0 | VSS ₁ (Ground ₁) | VSS ₁ (Ground ₁) |
| 3 | Not Used | /SS | VDD ₁ | VDD ₁ |
| 4 | Out 2 | SCLK | Test 0 ₁ | Test 0 ₁ |
| 5 | Out 1 | MOSI / MISO | Not Used | /SS ₂ |
| 6 | Test 1 | Test 1 | Out 2 ₂ | SCLK ₂ |
| 7 | VDIG | VDIG | Out 1 ₂ | MOSI ₂ / MISO ₂ |
| 8 | Vss (Ground) | Vss (Ground) | Test 1 ₂ | Test 1 ₂ |
| 9 | | | VDIG ₂ | VDIG ₂ |
| 10 | | | VSS ₂ (Ground ₂) | VSS ₂ (Ground ₂) |
| 11 | | | VDD ₂ | VDD ₂ |
| 12 | | | Test 0 ₂ | Test 0 ₂ |
| 13 | | | Not Used | /SS ₁ |
| 14 | | | Out 2 ₁ | SCLK ₁ |
| 15 | | | Out 1 ₁ | MOSI ₁ / MISO ₁ |
| 16 | | | Test 1 ₁ | Test 1 ₁ |

For optimal EMC behavior, it is recommended to connect the unused pins (Not Used and Test) to the Ground (see section 16).

² See Section 14.1 for the Out 1 and Out 2 configuration

5. Absolute Maximum Ratings

| Parameter | Value |
|--|--|
| Supply Voltage, VDD (overvoltage) | + 20 V |
| Reverse Voltage Protection | - 10 V |
| Positive Output Voltage (Analog or PWM) Both outputs OUT 1 & OUT 2 | + 10 V + 14 V (200 s max - T _A = + 25°C) |
| Output Current (I _{OUT}) | ± 30 mA |
| Reverse Output Voltage Both outputs OUT 1 & OUT 2 | - 0.3 V |
| Reverse Output Current Both outputs OUT 1 & OUT 2 | - 50 mA |
| Operating Ambient Temperature Range, T _A | - 40°C ... + 150°C |
| Storage Temperature Range, T _S | - 40°C ... + 150°C |
| Magnetic Flux Density | ± 4 T |

Exceeding the absolute maximum ratings may cause permanent damage. Exposure to absolute-maximum-rated conditions for extended periods may affect device reliability.

6. Detailed Description

As described on the block diagram (Figure 1 and Figure 2), the magnetic flux density applied to the IC is sensed through the Tria[⊗]is™ sensor front-end. This front-end consists into two orthogonal pairs (for each of the two directions parallel with the IC surface i.e. X and Y) of conventional planar Hall plates (sensitive element – blue area on Figure 4) and an Integrated Magneto-Concentrator (IMC[®] yellow disk on Figure 4).

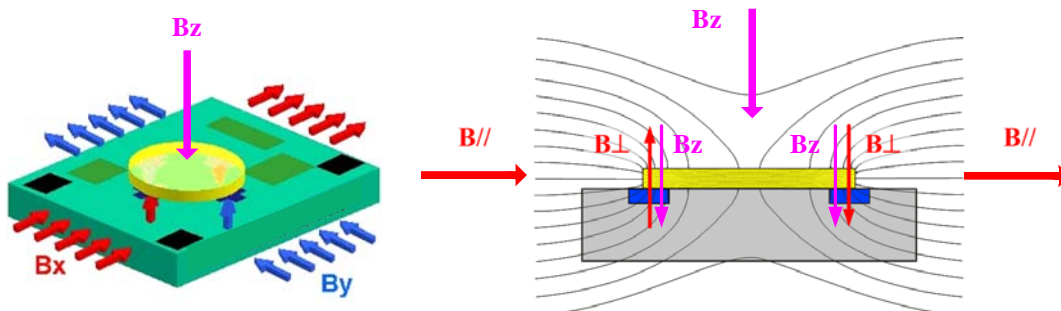

Figure 4 - Tria[⊗]is™ sensor front-end (4 Hall plates + IMC[®] disk)

Two orthogonal components (respectively $B_{x\perp}$ and $B_{y\perp}$) proportional to the parallel components (respectively $B_{x//}$ and $B_{y//}$) are induced through the IMC and can be measured by both respective pairs of conventional planar Hall plates as those are sensitive to the flux density applied orthogonally to them and the IC surface. The third component B_z is also sensed by those four (4) conventional Hall plates as shown above.

In summary, along X-axis, the left Hall plate measures “ $B_{X\perp} - B_Z$ ” while the right Hall plate measures “ $-B_{X\perp} - B_Z$ ”. Similarly, along the Y-axis, the left Hall plate measures “ $B_{Y\perp} - B_Z$ ” while the right Hall plate measures “ $-B_{Y\perp} - B_Z$ ”.

Through an appropriate signal processing, the Tria \otimes is™ sensor front-end reports the three (3) components of the applied magnetic flux density B i.e. B_x , B_y and B_z .

Indeed, by subtracting the signals from the two (2) Hall plates in each pair, the components $B_{X\perp}$ and $B_{Y\perp}$ are measured while B_z is cancelled. To the contrary, by adding the signals from the two (2) Hall plates in each pair, the component B_z is measured while $B_{X\perp}$ and $B_{Y\perp}$ are cancelled

In a joystick based on a “gimbal” mechanism as shown on Figure 3 (left), the magnet (axial magnetization) moves on a hemisphere centered at the IC. The flux density is described through the following relationships:

$$B_x = \sin(\alpha) \cdot \cos(\beta)$$

$$B_y = \cos(\alpha) \cdot \sin(\beta)$$

$$B_z = \cos(\alpha) \cdot \cos(\beta)$$

Those components are plotted on the Figure 5, Figure 6 and Figure 7.

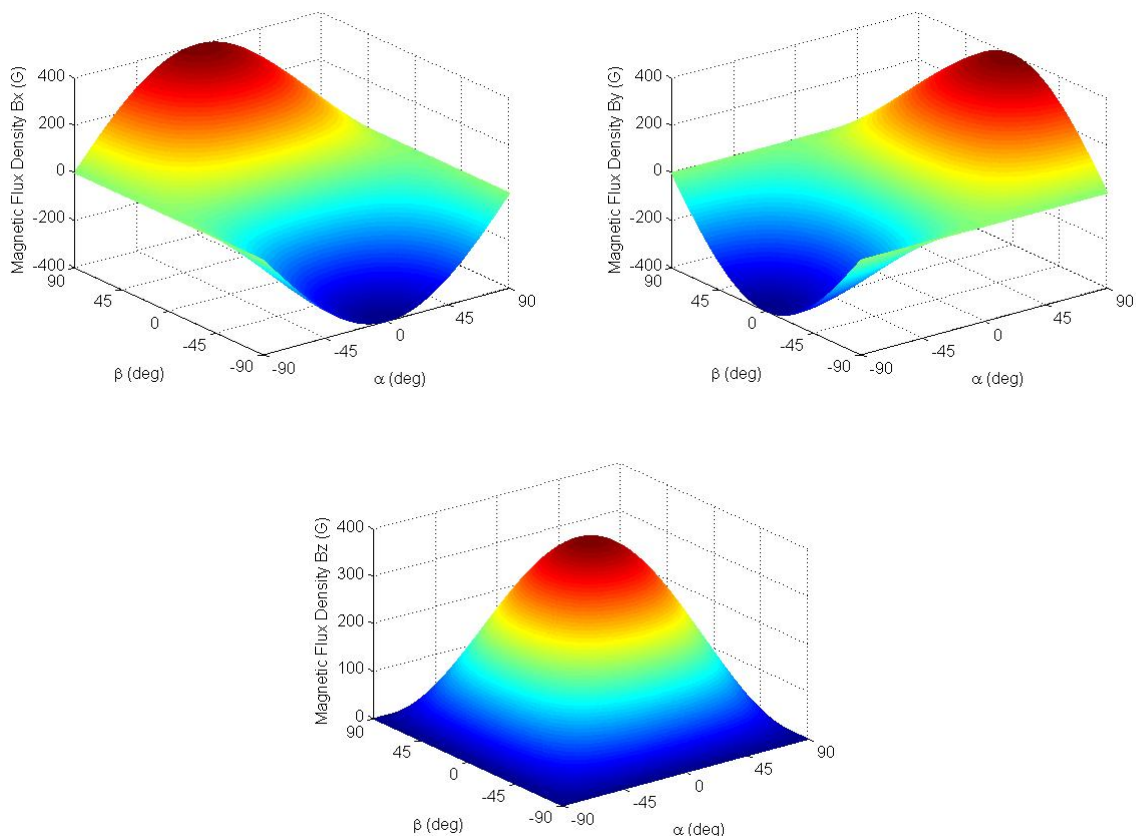

Figure 5 – Magnetic Flux Density – B_x , B_y , B_z

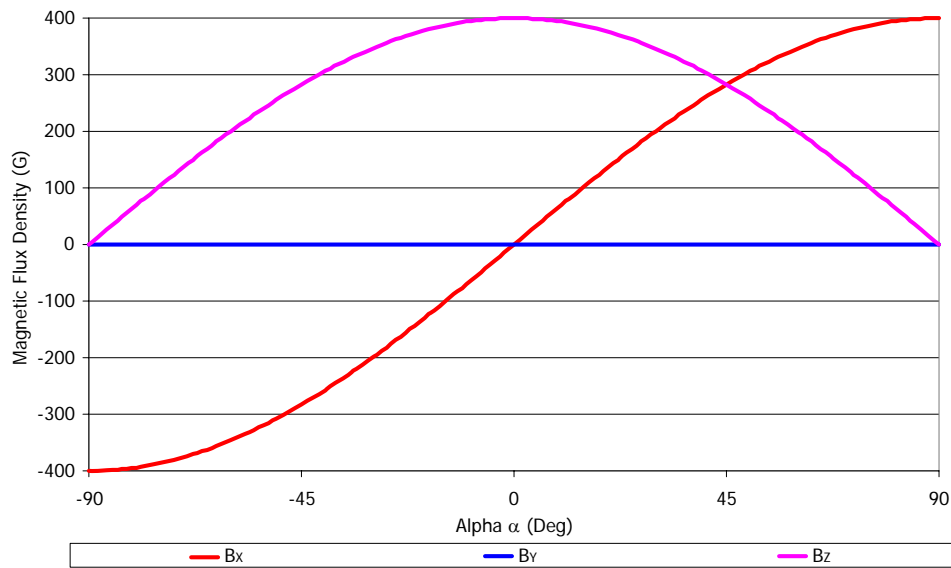

Figure 6 – Magnetic Flux Density – $\beta = 0$ Deg – $B_x \propto \sin(\alpha)$, $B_y = 0$ & $B_z \propto \cos(\alpha)$

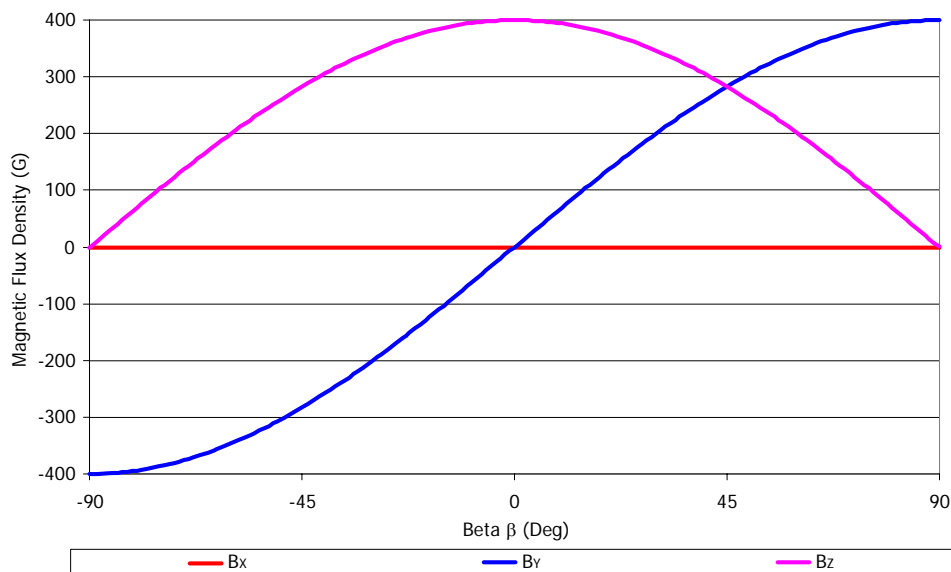

Figure 7 – Magnetic Flux Density – $\alpha = 0$ Deg – $B_x = 0$, $B_y \propto \sin(\beta)$ & $B_z \propto \cos(\beta)$

Three (3) differential voltages corresponding to the three (3) components of the applied flux density are provided to the ADC (Analog-to-Digital Converter – Figure 8 and Figure 9). The Hall signals are processed through a fully differential analog chain featuring the classic offset cancellation technique (Hall plate quadrature spinning and chopper-stabilized amplifier).

The amplitude of V_z is smaller than the other two (2) components V_x and V_y due to fact that the magnetic gain of the IMC only affects the components parallel to the IC surface.

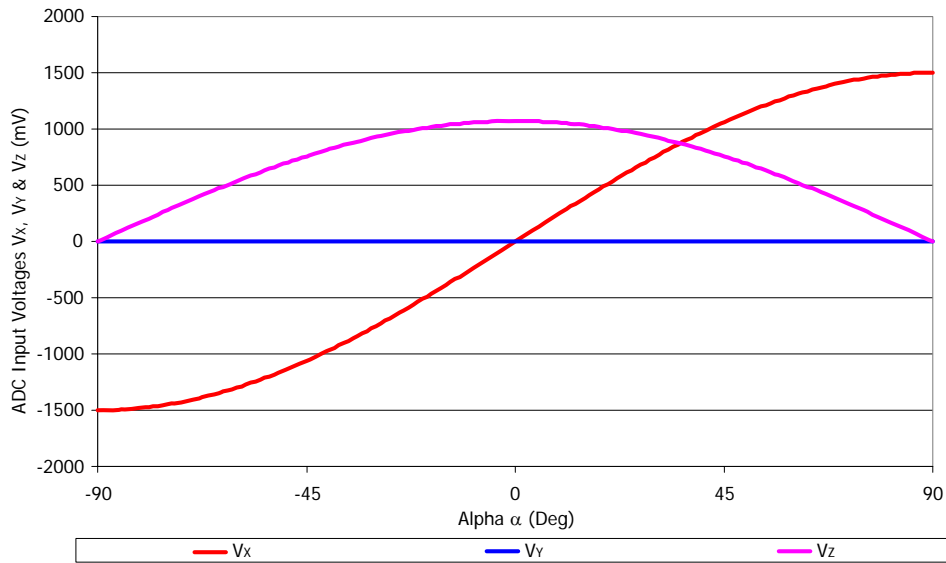

Figure 8 – ADC Input Signals – $\beta = 0$ Deg – $V_x \propto B_x \propto \sin(\alpha)$, $V_y = B_y = 0$ & $V_z \propto B_z \propto \cos(\alpha)$

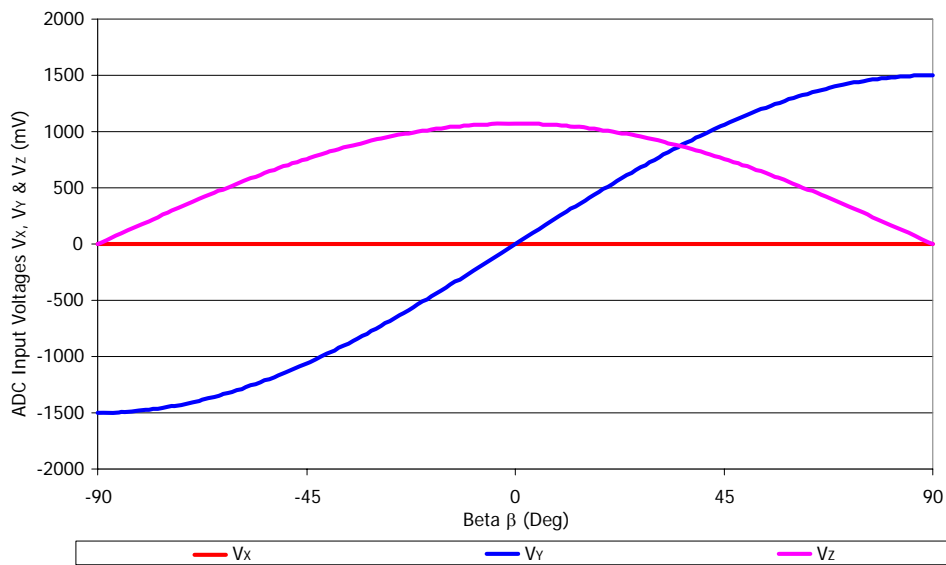

Figure 9 – ADC Input Signals – $\alpha = 0$ Deg – $V_x = B_x = 0$, $V_y \propto B_y \propto \sin(\beta)$ & $V_z \propto B_z \propto \cos(\beta)$

The conditioned analog signals are converted through an ADC (configurable – 14 or 15 bits) and provided to a DSP block for further processing. The DSP stage is based on a 16 bit RISC micro-controller whose primary function is the extraction of the two (2) angular information from the three (3) raw signals (after so-called front-end compensation steps) through the following operations:

$$\alpha = ATAN\left(\frac{k_z V_z}{V_x}\right)$$

$$\beta = ATAN\left(\frac{k_z V_z}{V_y}\right)$$

where k_z is a programmable parameter. First of all, k_z is used to compensate the smaller amplitude of V_z vs. V_x & V_y . On the other hand, k_z allows also a targeted reduction of the linearity error through a normalization of the raw signals prior to performing the “ATAN” function.

In a joystick based on a “ball & socket” joint as shown on Figure 3 (right), the magnet (axial magnetization) moves on a hemisphere centered at the pivot point. The flux density is described through slightly more complex equations but the MLX90333 offers an alternate algorithm to extract both angular informations:

$$\alpha = ATAN\left(\frac{\sqrt{(k_z V_z)^2 + (k_t V_y)^2}}{V_x}\right)$$

$$\beta = ATAN\left(\frac{\sqrt{(k_z V_z)^2 + (k_t V_x)^2}}{V_y}\right)$$

where k_z and k_t are programmable parameters.

The DSP functionality is governed by the micro-code (firmware – F/W) of the micro-controller which is stored into the ROM (mask programmable). In addition to the “ATAN” function, the F/W controls the whole analog chain, the output transfer characteristic, the output protocol, the programming/calibration and also the self-diagnostic modes.

In the MLX90333, the “ATAN” function is computed via a look-up table (i.e. it is not obtained through a CoRDIC algorithm).

Due to the fact that the “ATAN” operation is performed on the ratios “ V_z/V_x ” and “ V_z/V_y ”, the angular information are intrinsically self-compensated vs. flux density variations (due to airgap change, thermal or ageing effects) affecting the magnetic signal. This feature allows therefore an improved thermal accuracy vs. joystick based on conventional linear Hall sensors.

Once the angular information is computed (over 360 degrees), it is further conditioned (mapped) vs. the target transfer characteristic and it is provided at the output(s) as:

- an analog output level through a 12 bit DAC followed by a buffer
- a digital PWM signal with 12 bit depth (programmable frequency 100 Hz ... 1 kHz)
- a digital Serial Protocol (SP – 14 bits computed angular information available)

For instance, the analog output can be programmed for offset, gain and clamping to meet any rotary position sensor output transfer characteristic:

$$\begin{array}{ll} V_{out}(\alpha) = \text{ClampLo} & \text{for } \alpha \leq \alpha_{\min} \\ V_{out}(\alpha) = \text{Voffset} + \text{Gain} \times \alpha & \text{for } \alpha_{\min} \leq \alpha \leq \alpha_{\max} \\ V_{out}(\alpha) = \text{ClampHi} & \text{for } \alpha \geq \alpha_{\max} \end{array}$$

$$\begin{array}{ll} V_{out}(\beta) = \text{ClampLo} & \text{for } \beta \leq \beta_{\min} \\ V_{out}(\beta) = \text{Voffset} + \text{Gain} \times \beta & \text{for } \beta_{\min} \leq \beta \leq \beta_{\max} \\ V_{out}(\beta) = \text{ClampHi} & \text{for } \beta \geq \beta_{\max} \end{array}$$

where Voffset, Gain, ClampLo and ClampHi are the main adjustable parameters for the end-user.

The linear part of the transfer curve can be adjusted through a 3 point calibration. Once only one output is used, a 5 point calibration is also available for further improvement of the linearity.

The calibration parameters are stored in EEPROM featuring a Hamming Error Correction Coding (ECC).

The programming steps do not require any dedicated pins. The operation is done using the supply and output nodes of the IC. The programming of the MLX90333 is handled at both engineering lab and production line levels by the Melexis Programming Unit PTC-04 with the MLX90316 daughterboard and dedicated software tools (DLL – User Interface).

7. MLX90333 Electrical Specification

DC Operating Parameters at VDD = 5V (unless otherwise specified) and for TA as specified by the Temperature suffix (K or L).

| Parameter | Symbol | Test Conditions | Min | Typ | Max | Units |
|---|----------|---|----------------------------|------|------------------|---------------------|
| Nominal Supply Voltage | VDD | | 4.5 | 5 | 5.5 | V |
| Supply Current ⁽³⁾ | Idd | Slow mode ⁽⁴⁾ | | 8.5 | 11 | mA |
| | | Fast mode ⁽⁴⁾ | | 13.5 | 16 | mA |
| POR Level | VDD POR | Supply Under Voltage | 2 | 2.7 | 3 | V |
| Output Current Both outputs OUT 1 & OUT 2 | Iout | Analog Output mode | -8 | | 8 | mA |
| | | PWM Output mode | -20 | | 20 | mA |
| Output Short Circuit Current Both outputs OUT 1 & OUT 2 | Ishort | Vout = 0 V | | 12 | 15 | mA |
| | | Vout = 5 V | | 12 | 15 | mA |
| | | Vout = 14 V (TA = 25°C) | | 24 | 45 | mA |
| Output Load Both outputs OUT 1 & OUT 2 | RL | Pull-down to Ground | 1 | 10 | ∞ ⁽⁶⁾ | kΩ |
| | | Pull-up to 5V ⁽⁵⁾ | 1 | 10 | ∞ ⁽⁶⁾ | kΩ |
| Analog Saturation Output Level Both outputs OUT 1 & OUT 2 | Vsat_lo | Pull-up load RL ≥ 10 kΩ | | | 3 | %VDD |
| | Vsat_hi | Pull-down load RL ≥ 5 kΩ | 96 | | | %VDD |
| Digital Saturation Output Level Both outputs OUT 1 & OUT 2 | VsatD_lo | Pull-up Low Side RL ≥ 10 kΩ Push-Pull (IOUT = -20mV) | | | 1.5 | %VDD |
| | VsatD_hi | Push-Pull (IOUT = 20mV) | 97 | | | %VDD |
| Active Diagnostic Output Level Both outputs OUT 1 & OUT 2 | Diag_lo | Pull-down load RL ≥ 5 kΩ Pull-up load RL ≥ 10 kΩ | | | 1 1.5 | %VDD |
| | Diag_hi | Pull-down load RL ≥ 5 kΩ Pull-up load RL ≥ 5 kΩ | 96 98 | | | %VDD |
| Passive Diagnostic Output Level Both outputs OUT 1 & OUT 2 (Broken Track Diagnostic) ⁽⁷⁾ | BVssPD | Broken Vss & Pull-down load RL ≤ 10 kΩ | | | 4 ⁽⁷⁾ | %VDD |
| | BVssPU | Broken Vss ⁽⁷⁾ & Pull-up load RL ≥ 1kΩ | 99 | 100 | | %VDD |
| | BVDDPD | Broken VDD ⁽⁷⁾ & Pull-down load RL ≥ 1kΩ | | 0 | 1 | %VDD |
| | BVDDPU | Broken VDD & Pull-up load to 5V | No Broken Track diagnostic | | | %VDD |
| Clamped Output Level Both outputs OUT 1 & OUT 2 | Clamp_lo | Programmable | 0 | | 100 | %VDD ⁽⁸⁾ |
| | Clamp_hi | Programmable | 0 | | 100 | %VDD ⁽⁸⁾ |

³ For the dual version, the supply current is multiplied by 2

⁴ See section 14.5.1 for details concerning Slow and Fast mode

⁵ Applicable for output in Analog and PWM (Open-Drain) modes

⁶ RL < ∞ for output in PWM mode

⁷ For detailed information, see also section 15

⁸ Clamping levels need to be considered vs the saturation of the output stage (see Vsat_lo and Vsat_hi)

As an illustration of the previous table, the MLX90333 fits the typical classification of the output span described on the Figure 10.

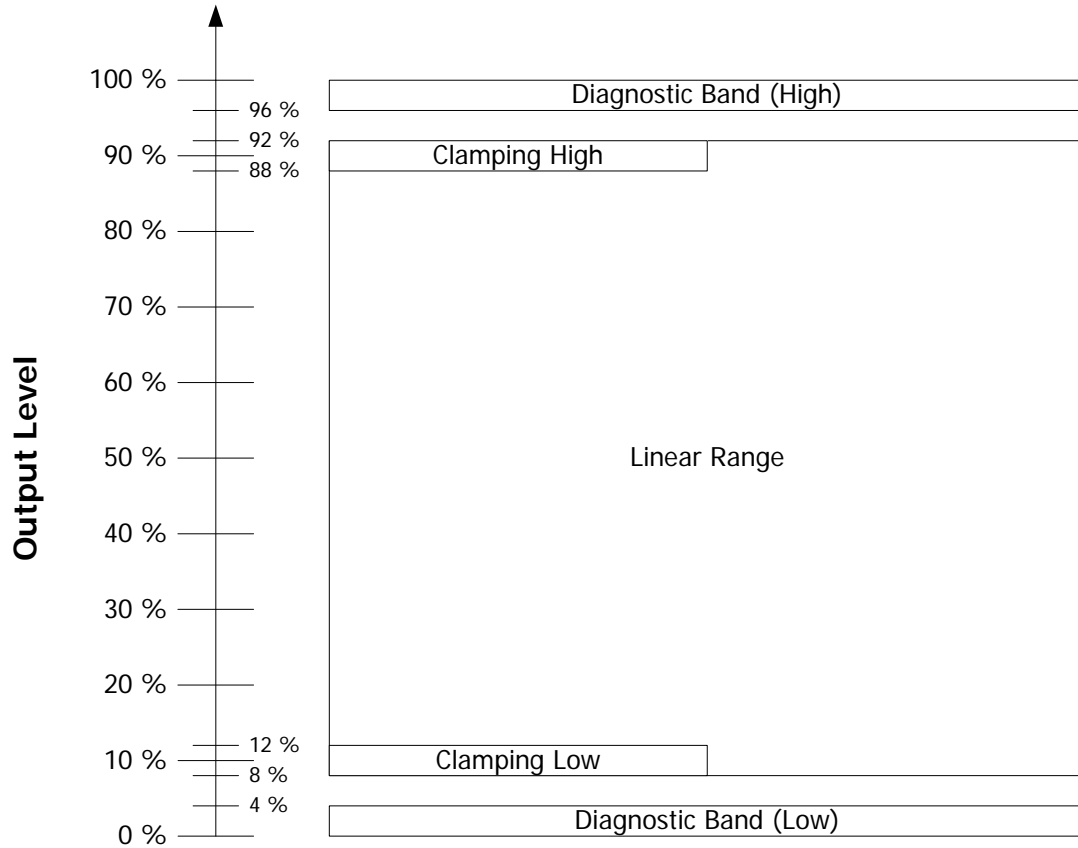

Figure 10 - Output Span Classification

8. MLX90333 Isolation Specification

DC Operating Parameters at VDD = 5V (unless otherwise specified) and for T_A as specified by the Temperature suffix (K or L). Only valid for the package code GO i.e. dual die version.

| Parameter | Symbol | Test Conditions | Min | Typ | Max | Units |
|----------------------|--------|-----------------|-----|-----|-----|-------|
| Isolation Resistance | | Between 2 dies | 4 | | | MΩ |

9. MLX90333 Timing Specification

DC Operating Parameters at VDD = 5V (unless otherwise specified) and for T_A as specified by the Temperature suffix (K or L).

| Parameter | Symbol | Test Conditions | Min | Typ | Max | Units |
|--|------------------|---|-----|-----|------|-------|
| Main Clock Frequency | Ck | Slow mode ⁽⁹⁾ | | 7 | | MHz |
| | | Fast mode ⁽⁹⁾ | | 20 | | MHz |
| Sampling Rate | | Slow mode ⁽¹⁰⁾ | | 600 | 1000 | μs |
| | | Fast mode ⁽¹⁰⁾ | | 200 | 330 | μs |
| Step Response Time | Ts | Slow mode ⁽⁹⁾ , Filter=5 ⁽¹⁰⁾ | | | 4 | ms |
| | | Fast mode ⁽⁹⁾ , Filter=0 ⁽¹⁰⁾ | | 400 | 600 | μs |
| Watchdog | Wd | See Section 15 | | | 5 | ms |
| Start-up Cycle | Tsu | Slow and Fast mode ⁽⁹⁾ | | | 15 | ms |
| Analog Output Slew Rate | | C _{OUT} = 42 nF | | 200 | | V/ms |
| | | C _{OUT} = 100 nF | | 100 | | |
| PWM Frequency | F _{PWM} | PWM Output Enabled | 100 | | 1000 | Hz |
| Digital Output Rise Time Both outputs OUT 1 & OUT 2 | | Mode 5 – 10nF, R _L = 10 kΩ | | 120 | | μs |
| | | Mode 7 – 10nF, R _L = 10 kΩ | | 2.2 | | μs |
| Digital Output Fall Time Both outputs OUT 1 & OUT 2 | | Mode 5 – 10nF, R _L = 10 kΩ | | 1.8 | | μs |
| | | Mode 7 – 10nF, R _L = 10 kΩ | | 1.9 | | μs |

⁹ See section 14.5.1 for details concerning Slow and Fast mode

¹⁰ See section 14.6 for details concerning Filter parameter

10. MLX90333 Accuracy Specification

DC Operating Parameters at VDD = 5V (unless otherwise specified) and for TA as specified by the Temperature suffix (K or L).

| Parameter | Symbol | Test Conditions | Min | Typ | Max | Units |
|--|---|--|--|-------|------|-------------------|
| ADC Resolution on the raw signals X, Y and Z | R _{ADC} | Slow Mode ⁽¹¹⁾ | | 15 | | bits |
| | | Fast Mode ⁽¹¹⁾ | | 14 | | bits |
| Offset on the Raw Signals X, Y and Z | X0, Y0, Z0 | TA = 25°C | -60 | | 60 | LSB ₁₅ |
| Mismatch on the Raw Signals X, Y and Z | SMISM _{XY} SMISM _{XZ} SMISM _{YZ} | TA = 25°C Between X and Y | -1 | | 1 | % |
| | | Between X and Z | End-User programmable ⁽¹²⁾ (k _t parameter) | | | |
| | | Between Y and Z | | | | |
| Thermal Offset Drift #1 on the raw signals X, Y and Z ⁽¹³⁾ | | Thermal Offset Drift at the DSP input (excl. DAC and output stage) | | | | |
| | | Temperature suffix K | -60 | | +60 | LSB ₁₅ |
| Thermal Offset Drift #2 (to be considered only for the analog output mode) | | Temperature suffix L | -90 | | +90 | LSB ₁₅ |
| | | Thermal Offset Drift of the DAC and Output Stage | | | | |
| Thermal Drift of Sensitivity Mismatch | | Temperature suffix K | -0.3 | | +0.3 | %VDD |
| | | Temperature suffix L | -0.4 | | +0.4 | %VDD |
| Analog Output Resolution | R _{DAC} | Temperature suffix K | -0.3 | | +0.3 | % |
| | | Temperature suffix L | -0.5 | | +0.5 | % |
| Output stage Noise | R _{DAC} | 12 bits DAC (Theoretical – Noise free) | | 0.025 | | %VDD/LSB |
| | | INL | -4 | | +4 | LSB |
| | | DNL | -1 | 0 | 1 | LSB |
| Output stage Noise | | Clamped Output | | 0.05 | | %VDD |
| Noise pk-pk ⁽¹⁴⁾ | | Gain = 14, Slow mode, Filter=5 | | 5 | 10 | LSB ₁₅ |
| | | Gain = 14, Fast mode, Filter=0 | | 10 | 20 | LSB ₁₅ |
| Ratiometry Error | | | -0.1 | 0 | 0.1 | %VDD |
| PWM Output Resolution | R _{PWM} | 12 bits (Theoretical – Jitter free) | | 0.025 | | %DC/LSB |
| PWM Jitter | J _{PWM} | Gain = 11, F _{PWM} = 250 Hz – 800Hz | | | 5 | LSB ₁₂ |
| Serial Protocol Output Resolution | R _{SPI} | Theoretical – Jitter free | | 14 | | bits |

¹¹ 15 bits corresponds to 14 bits + sign and 14 bits corresponds to 13 bits + sign. After angular calculation, this corresponds to 0.005Deg/LSB₁₅ in Low Speed Mode and 0.01Deg/LSB₁₄ in High Speed.

¹² The mismatch between X and Z (Y and Z) is end-user programmable through the 2 parameters k_z and k_t as described in the formulas page 11 in order to take into account the IC mismatch and system tolerances (magnetic and mechanical).

¹³ To evaluate the error affecting the computed angle i.e. “ATAN” function (See section 6), it is important to take into account the actual value of the factor k_z as it amplifies the signal V_z and consequently its drift too.

¹⁴ The application diagram used is described in the recommended wiring. For detailed information, refer to section Filter in application mode (Section 14.6).

11. MLX90333 Magnetic Specification

DC Operating Parameters at VDD = 5V (unless otherwise specified) and for T_A as specified by the Temperature suffix (K or L).

| Parameter | Symbol | Test Conditions | Min | Typ | Max | Units |
|--------------------------------|---------------------------------|-----------------|-------|-----|--------------------|--------|
| Magnetic Flux Density | B _x , B _y | | 20 | 50 | 70 ⁽¹⁵⁾ | mT |
| Magnetic Flux Density | B _z | | 24 | 75 | 140 | mT |
| Magnet Temperature Coefficient | TCm | | -2400 | | 0 | ppm/°C |

12. MLX90333 CPU & Memory Specification

The DSP is based on a 16 bit RISC μ Controller. This CPU provides 5 Mips while running at 20 MHz.

| Parameter | Symbol | Test Conditions | Min | Typ | Max | Units |
|-----------|--------|-----------------|-----|-----|-----|-------|
| ROM | | | | 10 | | kB |
| RAM | | | | 256 | | B |
| EEPROM | | | | 128 | | B |

¹⁵ Above 70 mT, the IMC starts saturating yielding to an increase of the linearity error.

13. MLX90333 End-User Programmable Items

| Parameter | Comments | Default Values | |
|-----------------|---|----------------|-------|
| | | - | # bit |
| MAINMODE | Select Outputs Configuration | 0 | 2 |
| Outputs Mode | Define the output stages mode | 2 | 3 |
| PWMPOL1 | PWM Polarity (Out 1) | 0 | 1 |
| PWMPOL2 | PWM Polarity (Out 2) | 0 | 1 |
| PWM_Freq | PWM Frequency | 1000h | 16 |
| 3-Points | 4 segments transfer curve for single angle output | 0 | 1 |
| ALPHA_POL | Revert the Sign of Alpha | 0 | 1 |
| ALPHA_MOD180 | Modulo Operation (180deg) on Alpha | 1 | 1 |
| ALPHA_DP | Alpha Discontinuity Point | 0 | 8 |
| ALPHA_DEADZONE | Alpha Dead Zone | 0 | 6 |
| ALPHA_S0 | Initial Slope | 4000h | 16 |
| ALPHA_X | Alpha X Coordinate | 4000h | 16 |
| ALPHA_Y | Alpha Y Coordinate | 8000h | 16 |
| ALPHA_S1 | Alpha S Coordinate | 4000h | 16 |
| BETA_POL | Revert the Sign of Beta | 0 | 1 |
| BETA_MOD180 | Modulo Operation (180deg) on Beta | 1 | 1 |
| BETA_DP | Beta Discontinuity Point | 0 | 6 |
| BETA_DEADZONE | Beta Dead Zone | 0 | 8 |
| BETA_S0 | Beta Dead Zone | 4000h | 16 |
| BETA_X | Beta X Coordinate | 4000h | 16 |
| BETA_Y | Beta Y Coordinate | 8000h | 16 |
| BETA_S1 | Beta S Coordinate | 4000h | 16 |
| CLAMP_LOW | Clamping Low | 0% | 16 |
| CLAMP_HIGH | Clamping High | 100% | 16 |
| 2D | | 0 | 1 |
| XYZ | SPI Only | 0 | 1 |
| KZ | | B3h | 8 |
| KT | | 80h | 8 |
| FIELDTHRES_LOW | | 0h | 8 |
| FIELDTHRES_HIGH | | 0h | 8 |
| DERIVGAIN | | 40h | 8 |
| FILTER | | 3 | 8 |
| FILTER A1 | Filter coefficient A1 for FILTER=6 | 6600h | 16 |
| FILTER A2 | Filter coefficient A2 for FILTER=6 | 2A00h | 16 |
| FILTERFIRST | | 0 | 1 |
| FHYST | | 0 | 8 |
| MELEXISID1 | | MLX | 16 |
| MELEXISID2 | | MLX | 16 |
| MELEXISID3 | | MLX | 16 |
| CUSTOMERID1 | | 1 | 16 |

End-User Programmable Items continues...

| ... End-User Programmable Items | | | |
|---------------------------------|--|-------|----|
| CUSTOMERID2 | | 17d | 16 |
| CUSTOMERID3 | | MLX | 16 |
| HIGHSPEED | | 0 | 1 |
| GAINMIN | | 0 | 8 |
| GAINMAX | | 41d | 8 |
| EEHAMHOLE | | 3131h | 16 |
| RESONFAULT | | 0 | 2 |
| MLXLOCK | | 0 | 1 |
| LOCK | | 0 | 1 |

14. Description of End-User Programmable Items

14.1. Output Configuration

The parameter MAINMODE defines the output stages configuration

| MAINMODE | OUT1 | OUT2 |
|----------|-------|----------------|
| 0 | ALPHA | BETA |
| 1 | BETA | ALPHA |
| 2 | ALPHA | ALPHA DERIVATE |
| 3 | BETA | BETA DERIVATE |

14.2. Output Mode

The MLX90333 outputs type is defined by the Output Mode parameter.

| Parameter | Value | Description |
|--------------------|-------|---------------------|
| Analog Output Mode | 2 | Analog Rail-to-Rail |
| PWM Output Mode | 5 | Low Side (NMOS) |
| | 7 | Push-Pull |
| Serial | N/A | Low Side (NMOS) |

14.2.1. Analog Output Mode

The Analog Output Mode is a rail-to-rail and ratiometric output with a push-pull output stage configuration allows the use of a pull-up or pull-down resistor.

14.2.2. PWM Output Mode

If one of the PWM Output modes is selected, the output signal is a digital signal with Pulse Width Modulation (PWM).

In mode 5, the output stage is an open drain NMOS transistor (low side), to be used with a pull-up resistor to VDD.

In mode 7, the output stage is a push-pull stage for which Melexis recommends the use of a pull-up resistor to VDD.

The PWM polarity of the Out 1 (Out 2) is selected by the PWMPOL1 (PWMPOL2) parameter:

- PWMPOL1 (PWMPOL2) = 0 for a low level at 100%
- PWMPOL1 (PWMPOL2) = 1 for a high level at 100%

The PWM frequency is selected by the PWM_Freq parameter.

| PWM Frequency Code | | | | |
|--------------------|---------------------------------------|-------|-------|-------|
| Oscillator Mode | Pulse-Width Modulation Frequency (Hz) | | | |
| | 100 | 200 | 500 | 1000 |
| Low Speed | 35000 | 17500 | 7000 | 3500 |
| High Speed | - | 50000 | 20000 | 10000 |

For instance, in Low Speed Mode, set PWM_Freq = 7000 (decimal) to set the PWM frequency at 500Hz.

14.2.3. Serial Protocol Output Mode

The MLX90333 features a digital Serial Protocol mode. The MLX90333 is considered as a Slave node. The frame layer type is defined by the parameter XYZ as described in the next table.

| Parameter | Value | Description |
|-----------|-------|-------------------------------|
| XYZ | 0 | Regular SPI Frame Alpha, Beta |
| | 1 | X,Y, Z Frame |

See the dedicated Serial Protocol section for a full description (Section 16).

14.3. Output Transfer Characteristic

| Parameter | Value | Description |
|-----------|-------|---|
| 3-Points | 0 | Regular Alpha, Beta Output (2 times 2 segments) |
| | 1 | Alpha (or Beta) Single Output (1 time 4 segments) |

The 3-Points parameters allow the user to use the 3-points mapping (4 segments). This mode can only be used for Mainmode equals 2 and 3.

- 3-Points = 0, the parameters list is described as bellow (Angle Alpha and Beta):

| Parameter | Value | Unit |
|-----------------------------|----------------|-------|
| ALPHA_POL BETA_POL | 0 1 | |
| ALPHA_MOD180 BETA_MOD180 | 0 1 | |
| ALPHA_DP BETA_DP | 0 ... 359.9999 | deg |
| ALPHA_X BETA_X | 0 ... 359.9999 | deg |
| ALPHA_Y BETA_Y | 0 ... 100 | % |
| ALPHA_S0 | 0 ... 17 | %/deg |

| | | |
|---------------------------------|----------------|-----|
| ALPHA_S1 BETA_S0 BETA_S1 | | |
| CLAMP_LOW | 0 ... 100 | % |
| CLAMP_HIGH | 0 ... 100 | % |
| ALPHA_DEADZONE BETA_DEADZONE | 0 ... 359.9999 | deg |

- 3-Points = 1, the parameters list is described as bellow (Alpha or Beta):

| Parameter | Value | Unit |
|-------------------------------|-------------------|-------|
| ALPHA_POL | 0 → CCW 1 → CW | |
| DP | 0 ... 359.9999 | deg |
| LNR_A_X LNR_B_X LNR_C_X | 0 ... 359.9999 | deg |
| LNR_A_Y LNR_B_Y LNR_C_Y | 0 ... 100 | % |
| LNR_S0 LNR_A_S LNR_B_S | 0 ... 17 | %/deg |
| LNR_C_S | -17... 0 ... 17 | %/deg |
| CLAMP_LOW | 0 ... 100 | % |
| CLAMP_HIGH | 0 ... 100 | % |
| DEADZONE | 0 ... 359.9999 | deg |

14.3.1. The Polarity and Modulo Parameters

The angle Alpha is defined as the arctangent of Z/X and Beta as the arctangent of Z/Y. It is possible to invert the polarity of these angles via the parameters ALPHA_POL and BETA_POL set to "1".

The MLX90313 can also be insensitive to the field polarity by setting the ALPHA_MOD180/BETA_MOD180 to "1".

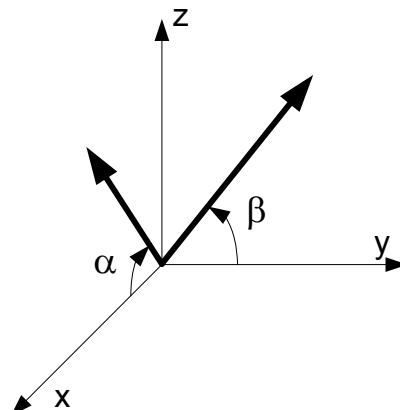

14.3.2. Alpha/Beta Discontinuity Point (or Zero Degree Point)

The Discontinuity Point defines the zero point of the circle (Alpha or Beta). The discontinuity point places the origin at any location of the trigonometric circle (see Figure 13). For a Joystick Application, Melexis recommends to set the DP to zero.

14.3.3. LNR Parameters

The LNR parameters, together with the clamping values, fully define the relation (the transfer function) between the digital angles (Alpha and Beta) and the output signals. The shape of the MLX90333 transfer function from the digital angle values to the output voltages is described by the drawing below (See Figure 11). Four segments can be programmed but the clamping levels are necessarily flat (3-Points = 0).

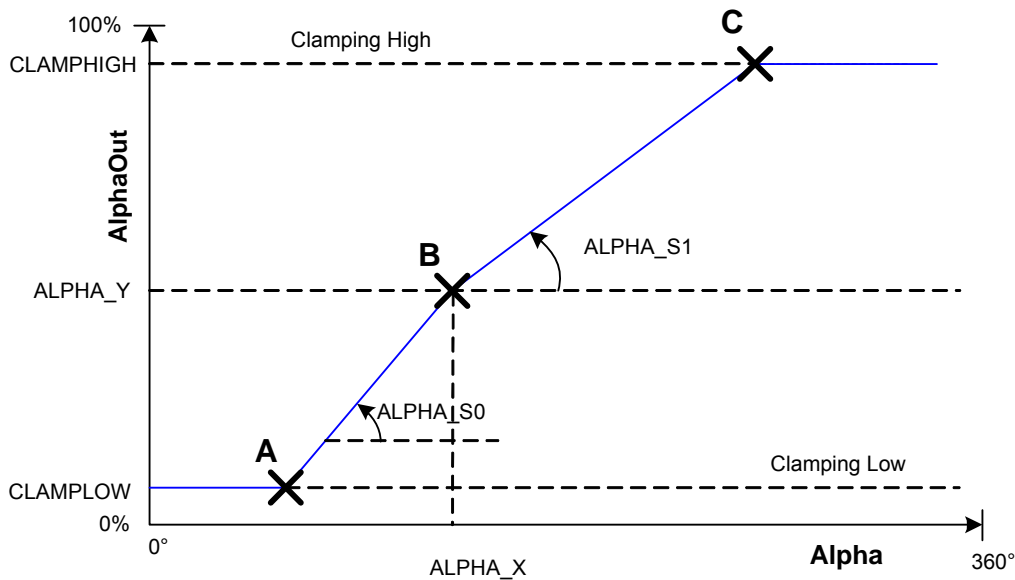

Figure 11 - Digital Angle (Alpha) Transfer Characteristic (Idem ditto for Beta)

In the case of one single angle output (3-Points = 1), the shape of the MLX90333 transfer function from the digital angle values to the output voltage is described by the drawing below (See Figure 12). Six segments can be programmed but the clamping levels are necessarily flat.

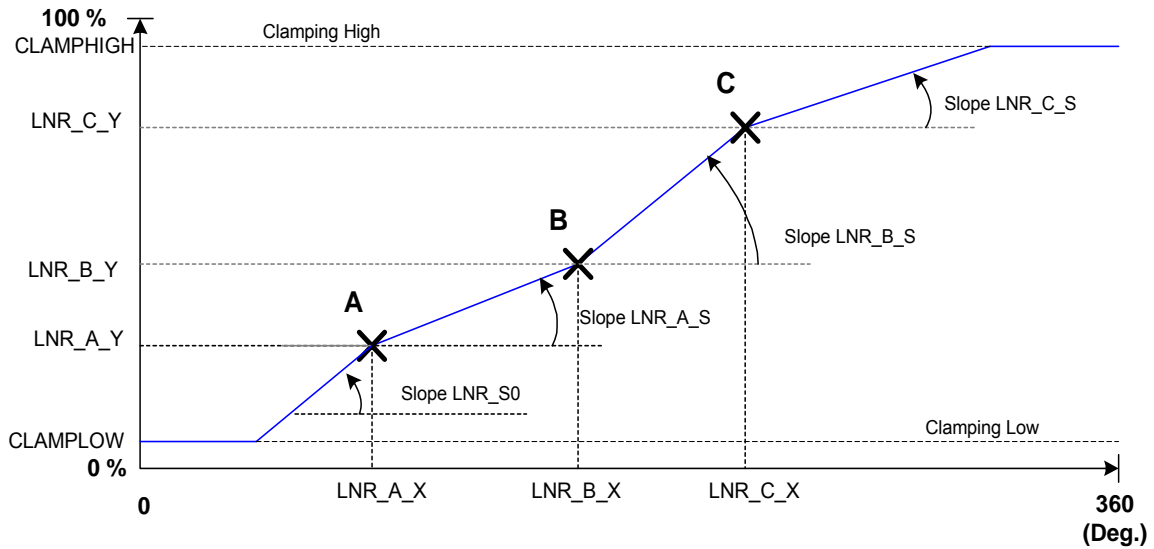

Figure 12 – Digital Angle (Alpha) Transfer Characteristic for Single Angle Output

14.3.4. CLAMPING Parameters

The clamping levels are two independent values to limit the output voltage range. The CLAMP_LOW parameter adjusts the minimum output voltage level. The CLAMP_HIGH parameter sets the maximum output voltage level. Both parameters have 16 bits of adjustment. In analog mode, the resolution will be limited by the D/A converter (12 bits) to 0.024%V_{DD}. In PWM mode, the resolution will be 0.024%DC. In SPI mode, the resolution is 14bits or 0.022deg over 360deg.

14.3.5. DEADZONE Parameter

The dead zone is defined as the angle window between 0 and 359.9999 (See Figure 13). When the digital angle (Alpha or Beta) lies in this zone, the IC is in fault mode (RESONFAULT must be set to “1” – See 14.7.1).

In case of ALPHA_MOD180 (or BETA_MOD180) is not set, the angle between 180° and 360° will generate a “deadzone” fault, unless DEADZONE=0.

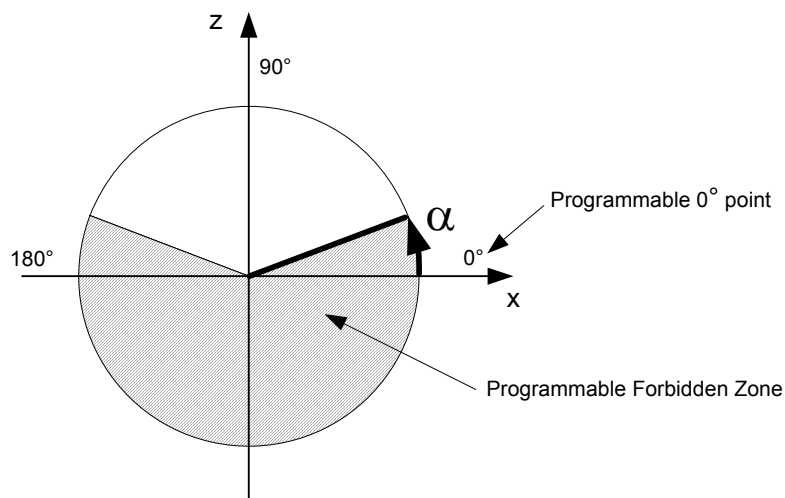

Figure 13 – Discontinuity Point and Dead Zone (Alpha – Idem ditto for Beta)

14.4. Identification

| Parameter | Value | Unit |
|-------------|-------------|------|
| MELEXSID1 | 0 ... 65535 | |
| MELEXSID2 | 0 ... 65535 | |
| MELEXSID3 | 0 ... 65535 | |
| CUSTOMERID1 | 0 ... 65535 | |
| CUSTOMERID2 | 0 ... 65535 | |
| CUSTOMERID3 | 0 ... 65535 | |

Identification number: 48 bits freely useable by Customer for traceability purpose.

14.5. Sensor Front-End

| Parameter | Value | Unit |
|----------------|--------------------------------|------|
| HIGHSPEED | 0 = Slow mode 1 = Fast mode | |
| GAINMIN | 0 ... 41 | |
| GAINMAX | 0 ... 41 | |
| FIELDTHRES_MIN | 0 ... 100 | % |
| FIELDTHRES_MAX | 0 ... 100 | % |

14.5.1. HIGHSPEED Parameter

The HIGHSPEED parameter defines the main frequency for the DSP.

- HIGHSPEED = 0 selects the Slow mode with a 7 MHz master clock.
- HIGHSPEED = 1 selects the Fast mode with a 20 MHz master clock.

For better noise performance, the Slow Mode must be enabled.

14.5.2. GAINMIN and GAINMAX Parameters

The MLX90333 features an automatic gain control (AGC) of the analog chain. The AGC loop is based on

$$\text{Max}(|V_x|, |V_y|, |V_z|) = |\text{Amplitude}| = \text{Radius}$$

and it targets an amplitude of 90% of the ADC input span.

The current gain can be read out with the programming unit PTC-04 and gives a rough indication of the applied magnetic flux density (Amplitude).

GAINMIN & GAINMAX define the boundaries within the gain setting is allowed to vary. Outside this range, the outputs are set in diagnostic low.

14.5.3. FIELDTHRES_MIN and FIELDTHRES_MAX Parameters

The strength of the applied field is constantly calculated in a background process. The value of this field can be read out with the PTC-04 and

FIELDTHRES_MIN & FIELDTHRES_MAX define the boundaries within the actual field strength (Radius) is allowed to vary. Outside this range, the outputs are set in diagnostic low.

14.6. FILTER

| Parameter | Value | Unit |
|-------------|----------------------|------|
| FHYST | 0 ... 11 ; step 0.04 | deg |
| FILTER | 0... 6 | |
| FILTERFIRST | 0 1 | |

The MLX90333 includes 3 types of filters:

- Hysteresis Filter: programmable by the FHYST parameter
- Low Pass FIR Filters controlled with the Filter parameter
- Low Pass IIR Filter controlled with the Filter parameter and the coefficients FILTER A1 and FILTER A2

Note: if the parameter FILTERFIRST is set to “1”, the filtering is active on the digital angle. If set to “0”, the filtering is active on the output transfer function.

14.6.1. Hysteresis Filter

The FHYST parameter is a hysteresis filter. The output value of the IC is not updated when the digital step is smaller than the programmed FHYST parameter value. The output value is modified when the increment is bigger than the hysteresis. The hysteresis filter reduces therefore the resolution to a level compatible with the internal noise of the IC. The hysteresis must be programmed to a value close to the noise level.

Please note that for the programmable version, the FHYST parameter is set to 4 by default. If you do not wish this feature, please set it to “0”.

14.6.2. FIR Filters

The MLX90333 features 6 FIR filter modes controlled with Filter = 0...5. The transfer function is described below:

$$y_n = \frac{1}{\sum_{i=0}^j a_i} \sum_{i=0}^j a_i x_{n-i}$$

The characteristics of the filters no 0 to 5 is given in the Table 1.

| Filter No (j) | 0 | 1 | 2 | 3 | 4 | 5 |
|--|-----------|-------------------------|--------|--------|--------|--------|
| Type | Disable | Finite Impulse Response | | | | |
| Coefficients a ₀ ... a ₅ | N/A | 110000 | 121000 | 133100 | 111100 | 122210 |
| Title | No Filter | Extra Light | | Light | | |
| 90% Response Time | 1 | 2 | 3 | 4 | 4 | 5 |
| 99% Response Time | 1 | 2 | 3 | 4 | 4 | 5 |
| Efficiency RMS (dB) | 0 | 2.9 | 4.0 | 4.7 | 5.6 | 6.2 |
| Efficiency P2P (dB) | 0 | 2.9 | 3.6 | 5.0 | 6.1 | 7.0 |

Table 1 - FIR Filters Selection Table

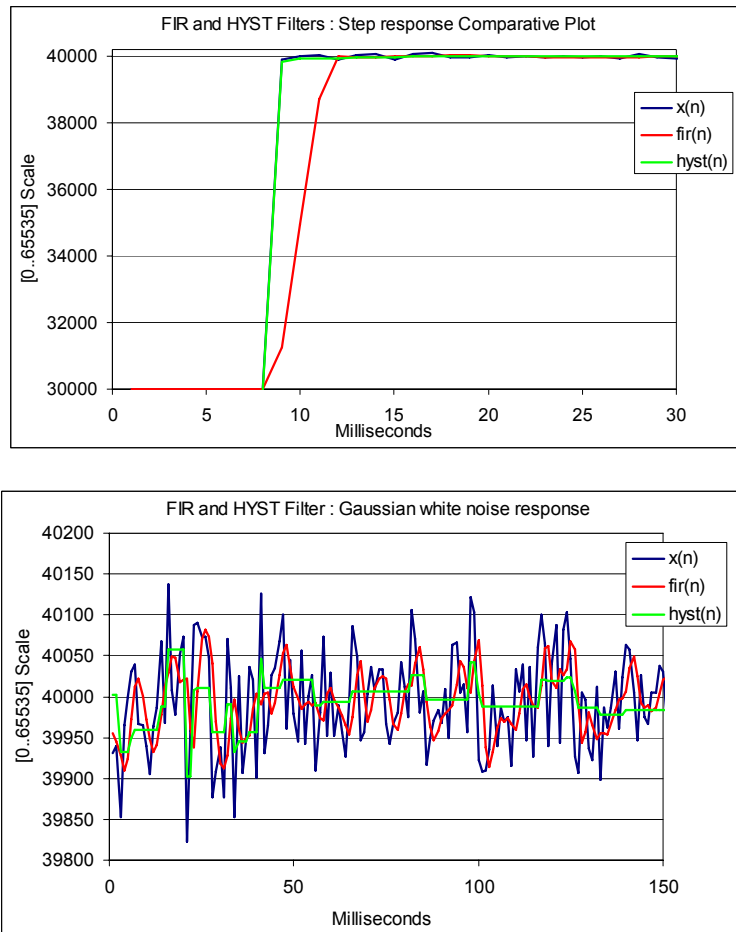

Figure 14 - Step Response and Noise Response for FIR (No 3) and FHYST=10

14.6.3. IIR Filters

The IIR Filter is enabled with Filter = 6. The diagram of the IIR Filter implemented in the MLX90333 is given in Figure 15. Only the parameter A1 and A2 are configurable (See Table 2).

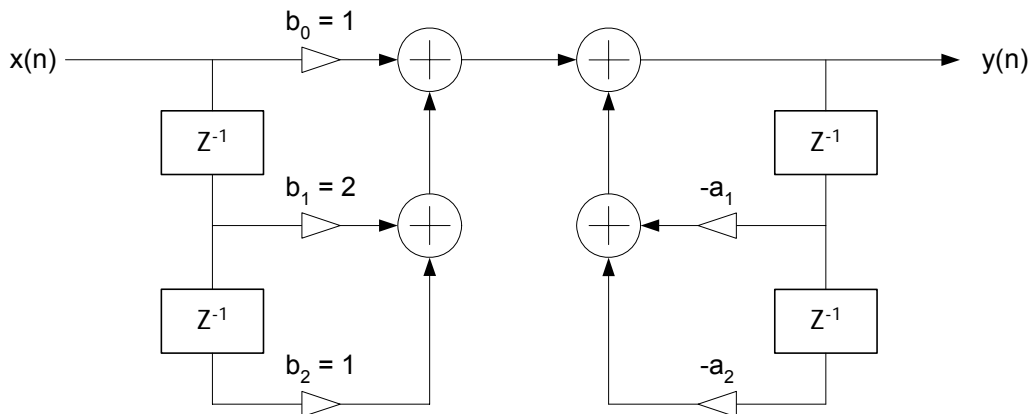

Figure 15 - IIR Diagram

| Filter No | 6 | | | | | |
|---------------------|---|-------|-------|-------|-------|-------|
| Type | 2 nd Order Infinite Impulse Response (IIR) | | | | | |
| Title | Medium & Strong | | | | | |
| 90% Response Time | 11 | 16 | 26 | 40 | 52 | 100 |
| Efficiency RMS (dB) | 9.9 | 11.4 | 13.6 | 15.3 | 16.2 | >20 |
| Efficiency P2P (dB) | 12.9 | 14.6 | 17.1 | 18.8 | 20 | >20 |
| Coefficient A1 | 26112 | 28160 | 29120 | 30208 | 31296 | 31784 |
| Coefficient A2 | 10752 | 12288 | 12992 | 13952 | 14976 | 15412 |

Table 2 - IIR Filter Selection Table

The Figure 16 shows the response of the filter to a Gaussian noise with default coefficient A1 and A2.

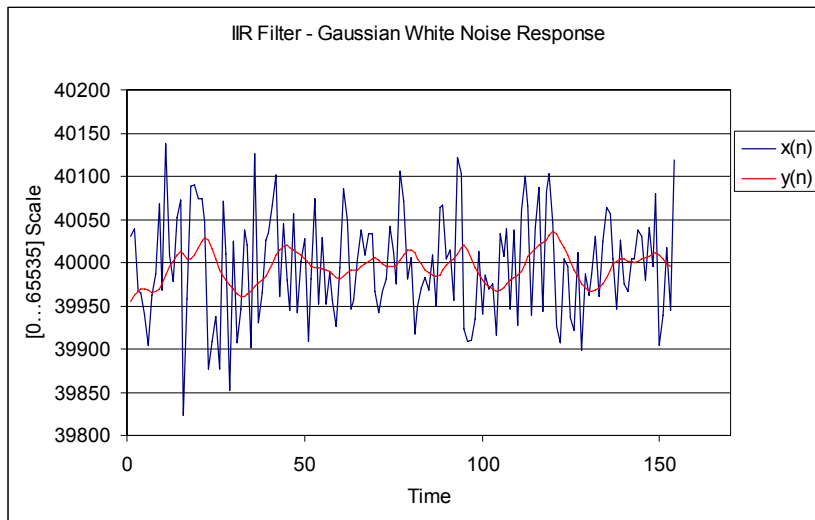

Figure 16 - Noise Response for the IIR Filter

14.7. Programmable Diagnostic Settings

| Parameter | Value | Unit |
|------------|-------|------|
| RESONFAULT | 0 | |
| | 1 | |
| EEHAMHOLE | 0 | |
| | 3131h | |

14.7.1. RESONFAULT Parameter

This RESONFAULT parameter enables the soft reset when a fault is detected by the CPU when the parameter is set to 1. By default, the parameter is set to “0” but it is recommended to set it to “1” to activate the self diagnostic modes (See section 15).

Note that in the User Interface (MLX90333UI), the RESONFAULT is a cluster of the following two bits, i.e. the 2 bits are both disabled or both enabled:

- DRESONFAULT: disable the reset in case of a fault.
- DOUTINFALT: disable output in diagnostic low in case of fault.

14.7.2. EEHAMHOLE Parameter

The EEHAMHOLE parameter disables the memory recovery (Hamming code) check when a fault is detected by the CRC when it is equal to 3131h. By default the parameter is set to 0 (enable memory recovery).

14.8. Lock

| Parameter | Value | Unit |
|-----------|-------|------|
| MLXLOCK | 0 | |
| | 1 | |
| LOCK | 0 | |
| | 1 | |

14.8.1. MLXLOCK Parameter

MLXLOCK locks all the parameters set by Melexis.

14.8.2. LOCK Parameter

LOCK locks all the parameters set by the user. Once the lock is enabled, it is not possible to change the EEPROM values anymore.

Note that the lock bit should be set by the solver function “MemLock”.

15. MLX90333 Self Diagnostic

The MLX90333 provides numerous self-diagnostic features. Those features increase the robustness of the IC functionality as it will prevent the IC to provide erroneous output signal in case of internal or external failure modes (“fail-safe”).

| | Action | Effect on Outputs | Remark |
|--|---|--------------------------------|---|
| ROM CRC Error at start up (64 words including Intelligent Watch Dog - IWD) | CPU Reset ⁽¹⁶⁾ | Diagnostic low ⁽¹⁷⁾ | All the outputs are already in Diagnostic low - (start-up) |
| ROM CRC Error (Operation - Background task) | Enter Endless Loop: - Progress (watchdog Acknowledge) - Set Outputs in Diagnostic low | Immediate Diagnostic low | |
| RAM Test Fail (Start up) | CPU Reset | Diagnostic low | All the outputs are already in Diagnostic low (start-up) |
| Calibration Data CRC Error (Start-Up) | Hamming Code Recovery | | Start-Up Time is increased by 3 ms if successful recovery |
| Hamming Code Recovery Error (Start-Up) | CPU Reset | Immediate Diagnostic low | See 14.7.2 |
| Calibration Data CRC Error (Operation - Background) | CPU Reset | Immediate Diagnostic low | |
| Dead Zone Alpha Dead Zone Beta | Set Outputs in Diagnostic low. Normal Operation until the “dead zone” is left. | Immediate Diagnostic low | Immediate recovery if the “dead zone” is left |
| ADC Clipping (ADC Output is 0000h or 7FFFh) | Set Outputs in Diagnostic low Normal mode and CPU Reset If recovery | Immediate Diagnostic low | |
| Radius Overflow (> 100%) or Radius Underflow (< 50 %) | Set Outputs in Diagnostic low Normal mode and CPU Reset If recovery | Immediate Diagnostic low | (50 % - 100 %) No magnet / field too high See also 14.5.2 |
| Field Clipping (Radius < FIELDTHRES_LOW or Radius > FIELDTHRES_HIGH) | Set Outputs in Diagnostic low Normal mode, and No CPU Reset If recovery | Immediate Diagnostic low | |
| Rough Offset Clipping (RO is < 0d or > 127d) | Set Outputs in Diagnostic low Normal mode, and CPU Reset If recovery | Immediate Diagnostic low | |
| Gain Clipping (Gain < GAINMIN or GAIN > GAINMAX) | Set Outputs in Diagnostic low Normal mode, and CPU Reset If recovery | Immediate Diagnostic low | See also 14.5.2 |
| DAC Monitor (Digital to Analog converter) | Set Outputs in Diagnostic low. Normal Mode with immediate recovery without CPU Reset | Immediate Diagnostic low | |
| <i>MLX90333 Fault Mode continues...</i> | | | |

¹⁶ CPU reset means

1. Core Reset (same as Power-On-Reset). It induces a typical start up time.
2. Periphery Reset (same as Power-On-Reset)
3. Fault Flag/Status Lost
4. The reset can be disabled by clearing the RESONFAULT bit (See 14.7.1)

¹⁷ Refer to section 7 for the Diagnostic Output Level specifications

| ...MLX90333 Fault Mode | | | |
|---|--|--|--|
| Fault Mode | Action | Effect on Outputs | Remark |
| ADC Monitor (Analog to Digital Converter) | Set Outputs in Diagnostic low. Normal Mode with immediate recovery without CPU Reset | Immediate Diagnostic low | ADC Inputs are Shorted |
| Undervoltage Mode | At Start-Up, wait Until VDD > 3V. During operation, CPU Reset after 3 ms debouncing | - VDD < POR level => Outputs high impedance - POR level < VDD < 3 V => Outputs in Diagnostic low. | |
| Firmware Flow Error | CPU Reset | Immediate Diagnostic low | Intelligent Watchdog (Observer) |
| Read/Write Access out of physical memory | CPU Reset | Immediate Diagnostic low | 100% Hardware detection |
| Write Access to protected area (IO and RAM Words) | CPU Reset | Immediate Diagnostic low | 100% Hardware detection |
| Unauthorized entry in "SYSTEM" Mode | CPU Reset | Immediate Diagnostic low | 100% Hardware detection |
| VDD > 7 V | Set Output High Impedance (Analog) | Pull down resistive load => Diag. Low Pull up resistive load => Diag. High ⁽¹⁷⁾ | 100% Hardware detection |
| VDD > 9.4 V | IC is switched off (internal supply) CPU Reset on recovery | Pull down resistive load => Diag. Low Pull up resistive load => Diag. High | No valid diagnostic for VPULLUP = VDD. Pull up load (≤ 10kΩ) to VPULLUP > 8 V to meet Diag Hi spec > 96% Vdd. |
| Broken Vss | CPU Reset on recovery | Pull down resistive load => Diag. Low Pull up resistive load => Diag. High | 100% Hardware detection. Pull down load ≤ 10 kΩ to meet Diag Low spec: - < 4% VDD (temperature suffix K) - contact Melexis for temperature suffix L |
| Broken VDD | CPU Reset on recovery | Pull down resistive load => Diag. Low Pull up resistive load => Diag. High | No valid diagnostic for VPULLUP = VDD. Pull up load (≤ 10kΩ) to VPULLUP > 8 V to meet Diag Hi spec > 96% Vdd. |

16. Serial Protocol

16.1. Introduction

The MLX90333 features a digital Serial Protocol mode. The MLX90333 is considered as a Slave node. The serial protocol of the MLX90333 is a three wires protocol (/SS, SCLK, MOSI-MISO):

- /SS pin is a 5 V tolerant digital input
- SCLK pin is a 5 V tolerant digital input
- MOSI-MISO pin is a 5 V tolerant open drain digital input/output

The basic knowledge of the standard SPI specification is required for the good understanding of the present section.

16.2. SERIAL PROTOCOL Mode

- CPHA = 1 → even clock changes are used to sample the data
- CPOL = 0 → active-Hi clock

The positive going edge shifts a bit to the Slave's output stage and the negative going edge samples the bit at the Master's input stage.

16.3. MOSI (Master Out Slave In)

The Master sends a command to the Slave to get the angle information.

16.4. MISO (Master In Slave Out)

The MISO of the slave is an open-collector stage. Due to the capacitive load (TBD) a >1 kΩ pull-up is used for the recessive high level (in fast mode). Note that MOSI and MISO use the same physical pin of the MLX90333.

16.5. /SS (Slave Select)

The /SS pin enables a frame transfer (if CPHA = 1). It allows a re-synchronization between Slave and Master in case of communication error.

16.6. Master Start-Up

/SS, SCLK, MISO can be undefined during the Master start-up as long as the Slave is re-synchronized before the first frame transfer.

16.7. Slave Start-Up

The slave start-up (after power-up or an internal failure) takes 16 ms. Within this time /SS and SCLK is ignored by the Slave. The first frame can therefore be sent after 16 ms. MISO is Hi-Z (i.e. Hi-Impedance) until the Slave is selected by its /SS input. MLX90333 will cope with any signal from the Master while starting up.

16.8. Timing

To synchronize communication, the Master deactivates /SS high for at least t_5 (1.5 ms). In this case, the Slave will be ready to receive a new frame. The Master can re-synchronize at any time, even in the middle of a byte transfer.

Note: Any time shorter than t_5 leads to an undefined frame state, because the Slave may or may not have seen /SS inactive.

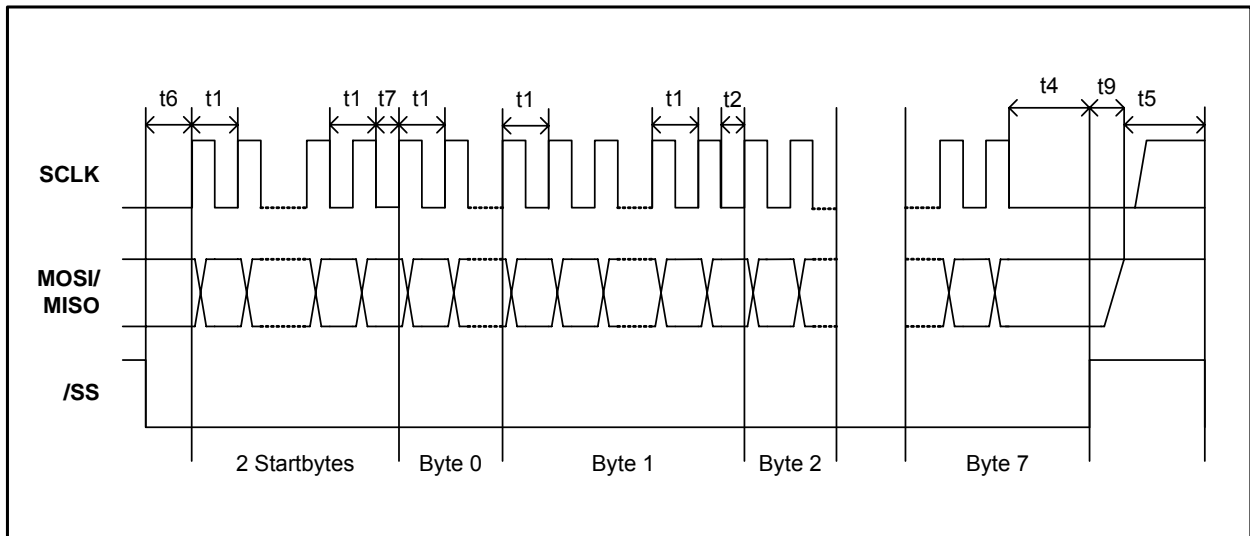

| Timings | Min ⁽¹⁸⁾ | Max | Remarks |
|----------------------|-----------------------------|-----------------|--|
| t1 | 2.3 μ s / 6.9 μ s | - | No capacitive load on MISO. t1 is the minimum clock period for any bits within a byte. |
| t2 | 12.5 μ s / 37.5 μ s | - | t2 the minimum time between any other byte |
| t4 | 2.3 μ s / 6.9 μ s | - | Time between last clock and /SS=high=chip de-selection |
| t5 | 300 μ s / 1500 μ s | - | Minimum /SS = Hi time where it's guaranteed that a frame re-synchronizations will be started. |
| t5 | 0 μ s | - | Maximum /SS = Hi time where it's guaranteed that NO frame re-synchronizations will be started. |
| t6 | 2.3 μ s / 6.9 μ s | - | The time t6 defines the minimum time between /SS = Lo and the first clock edge |
| t7 | 15 μ s / 45 μ s | - | t7 is the minimum time between the StartByte and the Byte0 |
| t9 | - | <1 μ s | Maximum time between /SS = Hi and MISO Bus High-Impedance |
| T _{StartUp} | - | < 10 ms / 16 ms | Minimum time between reset-inactive and any master signal change |

¹⁸ Timings shown for oscillator base frequency of 20MHz (Fast Mode) / 7 MHz (Slow Mode)

16.9. Slave Reset

On internal soft failures the Slave resets after 1 second or after an (error) frame is sent. On internal hard failures the Slave resets itself. In that case, the Serial Protocol will not come up. The serial protocol link is enabled only after the completion of the first synchronization (the Master deactivates /SS for at least t5).

16.10. Frame Layer

16.10.1. Frame Type Selection

See the programmable parameter XYZ in section 14.2.3 to select between the Alpha, Beta Frame and the X, Y, Z Frame.

16.10.2. Data Frame Structure

The Figure 17 gives the timing diagram for the SPI Frame. The latch point for the angle measurement is at the last clock before the first data frame byte.

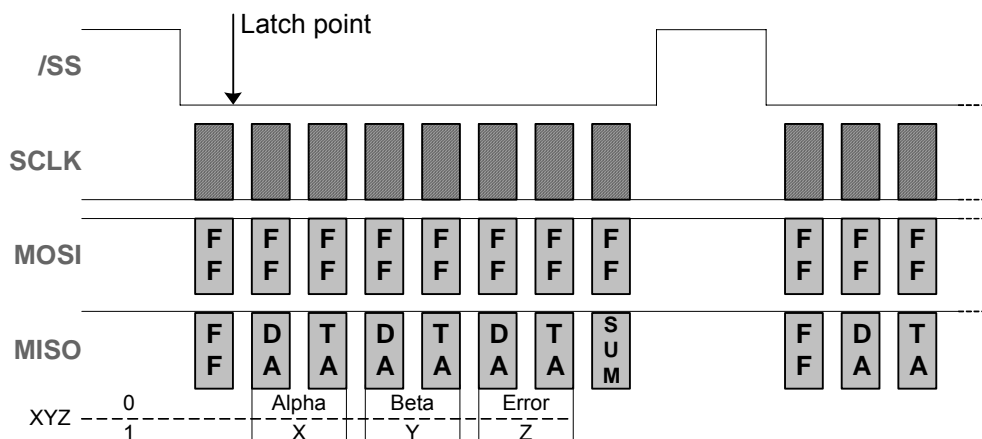

Figure 17 - Timing Diagram for the SPI Frame

A data frame consists of:

| Data Frame | XYZ = 0 | XYZ = 1 |
|-----------------------------|---|---------|
| 1 start byte | FFh | |
| 2 data bytes (LSByte first) | Alpha | X |
| 2 data bytes (LSByte first) | Beta | Y |
| 2 data bytes (LSByte first) | Error Code | Z |
| 1 SUM byte | 8 LSB of the sum of the transmitted bytes | |

16.10.3. Timing

There are no timing limits for frames: a frame transmission could be initiated at any time. There is no inter-frame time defined.

16.10.4. Data Structure

The DATA could be a valid angle/field component or an error condition. The two meanings are distinguished by the LSB.

DATA: Angle/ Field Component A[15:0] with (Span)/2¹⁶

| Less Significant Byte | | | | | | | | Most Significant Byte | | | | | | | |
|-----------------------|----|----|----|----|----|----|-----|-----------------------|-----|-----|-----|-----|-----|----|-----|
| msb | | | | | | | lsb | msb | | | | | | | lsb |
| A7 | A6 | A5 | A4 | A3 | A2 | A1 | A0 | A15 | A14 | A13 | A12 | A11 | A10 | A9 | A8 |

DATA: Error

| Less Significant Byte | | | | | | | | Most Significant Byte | | | | | | | |
|-----------------------|----|----|----|----|----|----|-----|-----------------------|-----|-----|-----|-----|-----|----|-----|
| msb | | | | | | | lsb | msb | | | | | | | lsb |
| E7 | E6 | E5 | E4 | E3 | E2 | E1 | E0 | E15 | E14 | E13 | E12 | E11 | E10 | E9 | E8 |

| BIT | NAME | |
|-----|-----------------|---|
| E0 | - | |
| E1 | - | |
| E2 | F_ADCMONITOR | ADC Failure |
| E3 | F_ADCSATURA | ADC Saturation (Electrical failure or field too strong) |
| E4 | F_GAINTOOLOW | The gain code is strictly less than EE_GAINMIN |
| E5 | F_GAINTOOHIGH | The gain code is strictly greater than EE_GAINMAX |
| E6 | F_NORMTOOLOW | Goes high when the fast norm (the max of absolute x,y,z) is below 30% |
| E7 | F_FIELDTOOLOW | The norm (Square root) is strictly less than EE_FIELDLOW |
| E8 | F_FIELDTOOHIGH | The norm (Square root) is strictly greater than EE_FIELDHIGH |
| E9 | F_ROCLAMP | Analog Chain Rough Offset Compensation: Clipping |
| E10 | - | |
| E11 | F_DEADZONEALPHA | The angle ALPHA lies in the deadzone |
| E12 | - | |
| E13 | - | |
| E14 | - | |
| E15 | F_DEADZONEBETA | The angle BETA lies in the deadzone |

16.10.5. Angle Calculation

All communication timing is independent (asynchronous) of the angle data processing. The angle is calculated continuously by the Slave:

- Slow Mode: every 1.5 ms at most.
- Fast Mode: every 350 μs at most.

The last angle calculated is hold to be read by the Master at any time. Only valid angles are transferred by the Slave, because any internal failure of the Slave will lead to a soft reset.

16.10.6. Error Handling

In case of any errors listed in section 16.10.4, the Serial protocol will be initialized and the error condition can be read by the master. The slave will perform a soft reset once the error frame is sent.

In case of any other errors (ROM CRC error, EEPROM CRC error, RAM check error, intelligent watchdog error...) the Slave's serial protocol is not initialized. The MOSI/MISO pin will stay Hi-impedant (no error frames are sent).

17. Recommended Application Diagrams

17.1. Analog Output Wiring with the MLX90333 in SOIC Package

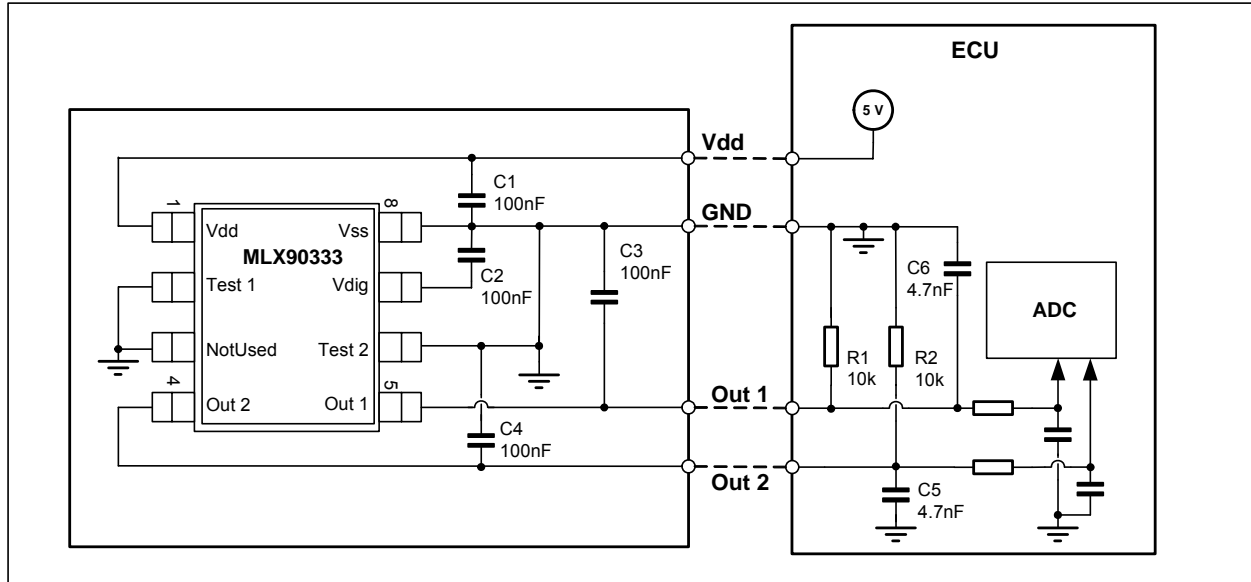

Figure 18 – Recommended wiring for the MLX90333 in SOIC8 package

17.2. PWM Low Side Output Wiring

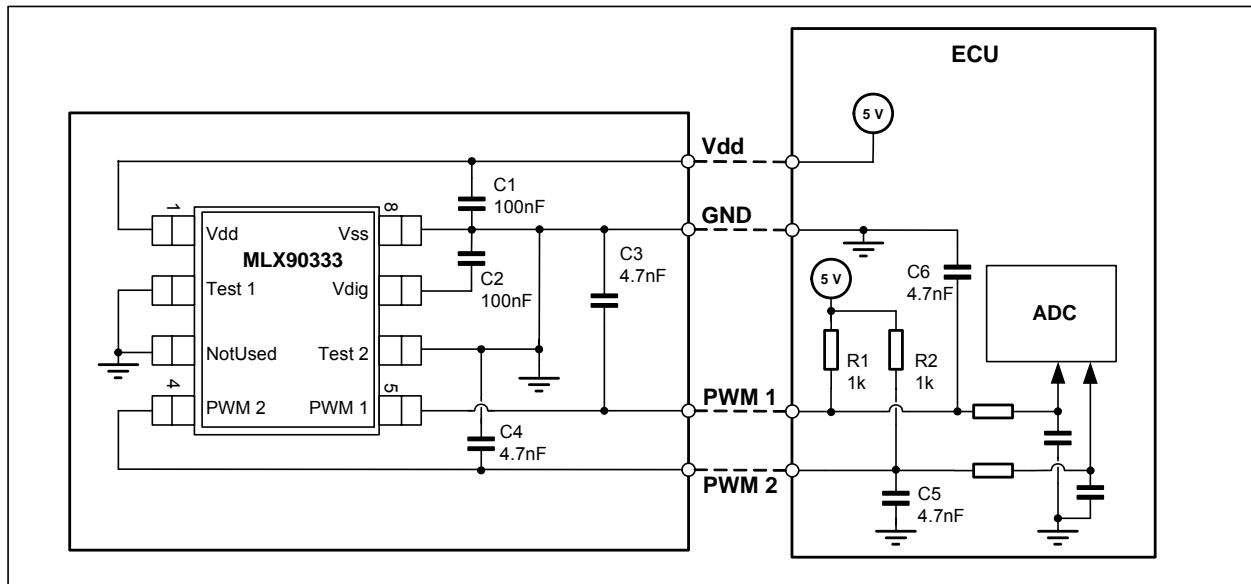

Figure 19 – Recommended wiring for a PWM Low Side Output configuration

17.3. Analog Output Wiring with the MLX90333 in TSSOP Package

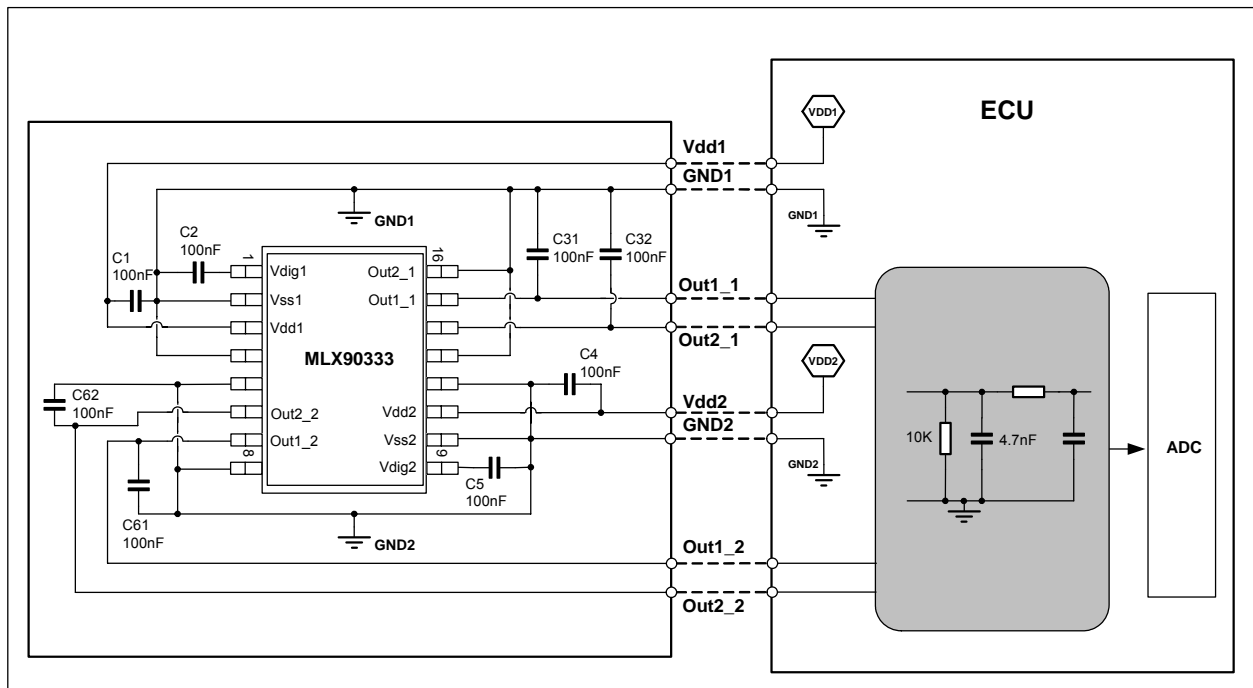

Figure 20 – Recommended wiring for the MLX90333 in TSSOP16 package (dual die).

17.4. Serial Protocol

Generic schematics for single slave and dual slave applications are described.

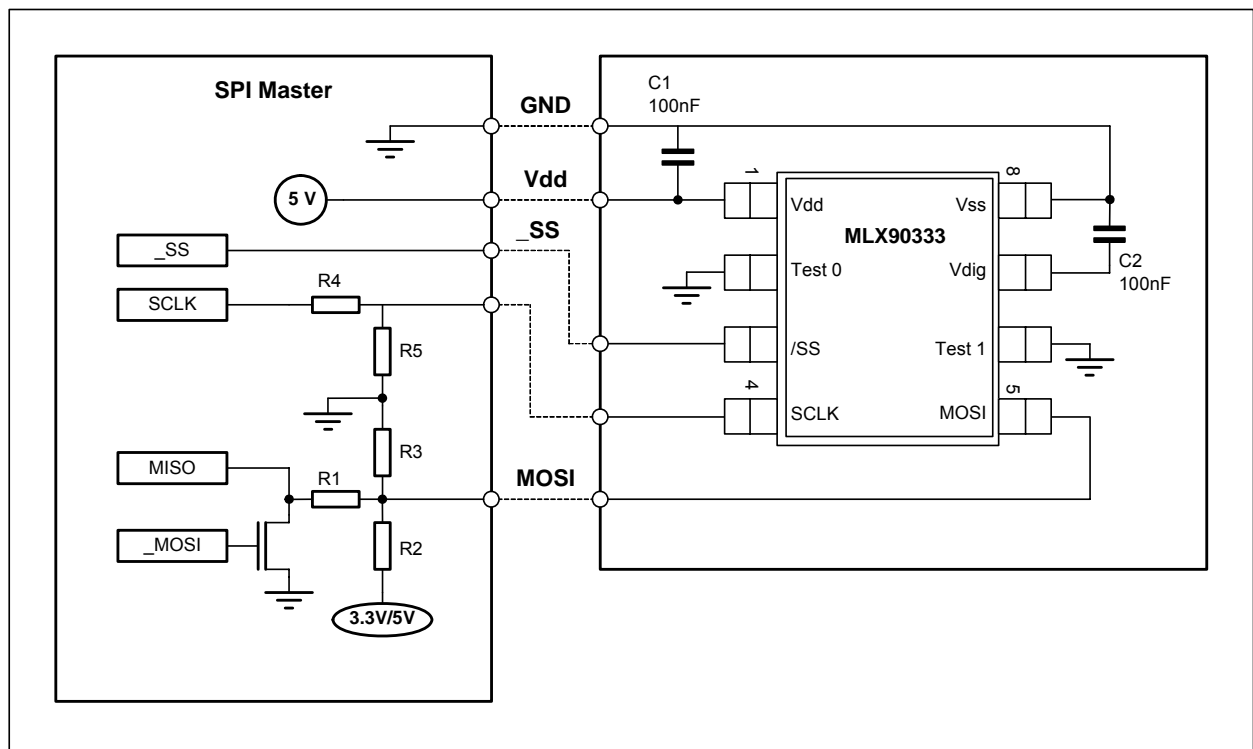

Figure 21 – MLX90333 – Single Die – Serial Protocol Mode

| Application Type | μCtrl Supply (V) | Pull-up Supply (V) | 90316 Supply (V) | R1 (Ω) | R2 (Ω) | R3 (Ω) | R4 (Ω) | R5 (Ω) | MOS Type |
|---|------------------|--------------------|------------------|--------|--------|--------|--------|--------|----------|
| 5V μCtrl w/o O.D. w/o 3.3V | 5V | 5V | 5V | 100 | 1000 | 20,000 | 1000 | 20,000 | BS170 |
| 5V μCtrl w/o O.D. w/ 3.3V | 5V | 3.3V | 5V | 150 | 1000 | N/A | 1000 | 20,000 | BS170 |
| 3.3V μCtrl w/o O.D. ⁽¹⁹⁾ | 3.3V | 3.3V | 5V | 150 | 1000 | N/A | N/A | N/A | BS170 |
| 5V μCtrl w/ O.D. w/o 3.3V ⁽²⁰⁾ | 5V | 5V | 5V | 100 | 1000 | 20,000 | 1000 | 20,000 | N/A |
| 3.3V μCtrl w/ O.D. | 3.3V | 3.3V | 5V | 150 | 1000 | N/A | N/A | N/A | N/A |

Table 3 - Resistor Values for Common Specific Applications

¹⁹ μCtrl w/ O.D. : Micro-controller with open-drain capability (for instance NEC V850ES series)

²⁰ μCtrl w/o O.D. : Micro-controller without open-drain capability (like TI TMS320 series or ATMEL AVR)

18. Standard information regarding manufacturability of Melexis products with different soldering processes

Our products are classified and qualified regarding soldering technology, solderability and moisture sensitivity level according to following test methods:

Reflow Soldering SMD's (Surface Mount Devices)

- IPC/JEDEC J-STD-020
Moisture/Reflow Sensitivity Classification for Nonhermetic Solid State Surface Mount Devices (Classification reflow profiles according to table 5-2)
- EIA/JEDEC JESD22-A113
Preconditioning of Nonhermetic Surface Mount Devices Prior to Reliability Testing (Reflow profiles according to table 2)
- Melexis Working Instruction 341901308

Wave Soldering SMD's (Surface Mount Devices) and THD's (Through Hole Devices)

- EN60749-20
Resistance of plastic- encapsulated SMD's to combined effect of moisture and soldering heat
- EIA/JEDEC JESD22-B106 and EN60749-15
Resistance to soldering temperature for through-hole mounted devices
- Melexis Working Instruction 341901309

Iron Soldering THD's (Through Hole Devices)

- EN60749-15
Resistance to soldering temperature for through-hole mounted devices
- Melexis Working Instruction 341901309

Solderability SMD's (Surface Mount Devices) and THD's (Through Hole Devices)

- EIA/JEDEC JESD22-B102 and EN60749-21
Solderability
- Melexis Working Instruction 3304312

For all soldering technologies deviating from above mentioned standard conditions (regarding peak temperature, temperature gradient, temperature profile etc) additional classification and qualification tests have to be agreed upon with Melexis.

The application of Wave Soldering for SMD's is allowed only after consulting Melexis regarding assurance of adhesive strength between device and board.

For more information on the lead free topic please see quality page at our website:
<http://www.melexis.com/quality.aspx>

19. ESD Precautions

Electronic semiconductor products are sensitive to Electro Static Discharge (ESD). Always observe Electro Static Discharge control procedures whenever handling semiconductor products.

20. Package Information

20.1. SOIC8 - Package Dimensions

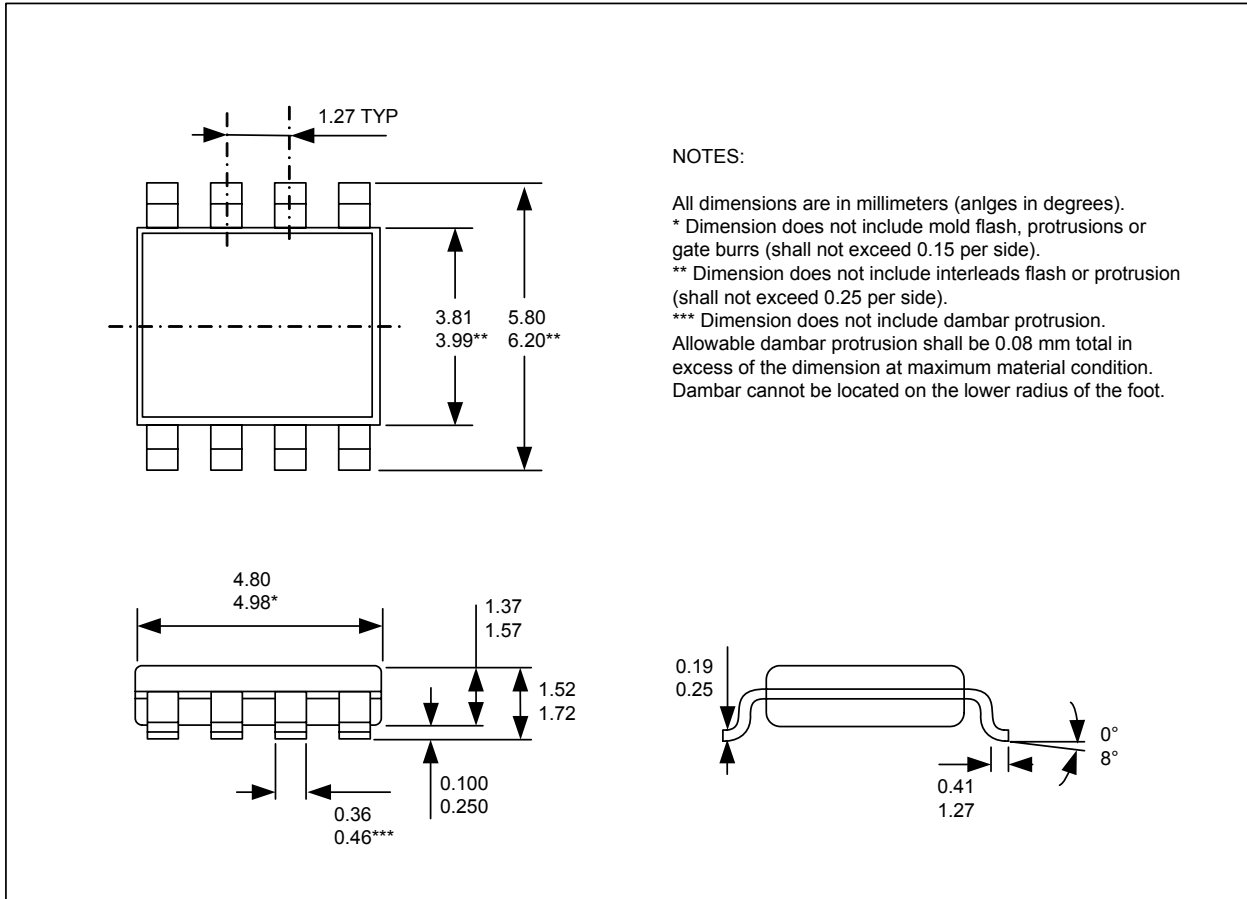

20.2. SOIC8 - Pinout and Marking

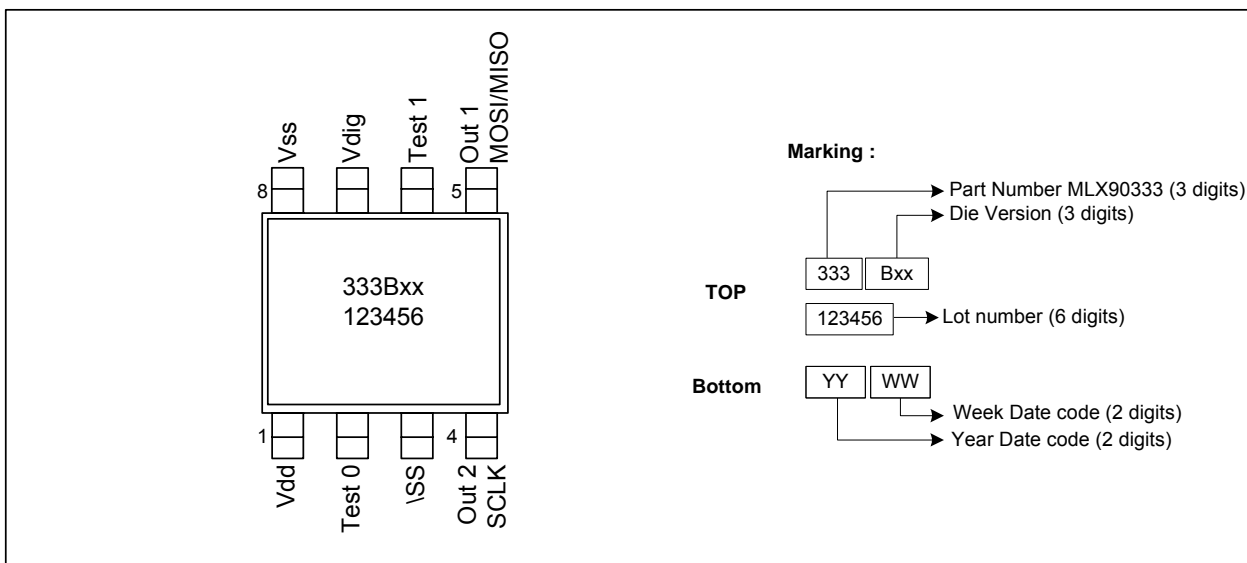

20.3. SOIC8 - IMC Positioning

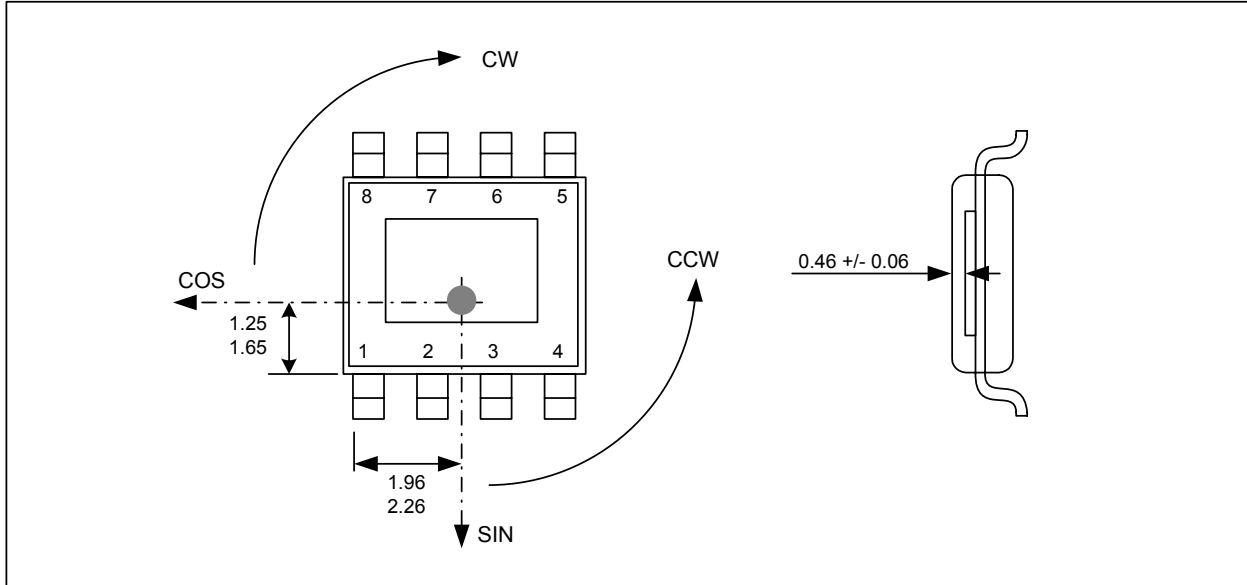

20.4. TSSOP16 - Package Dimensions

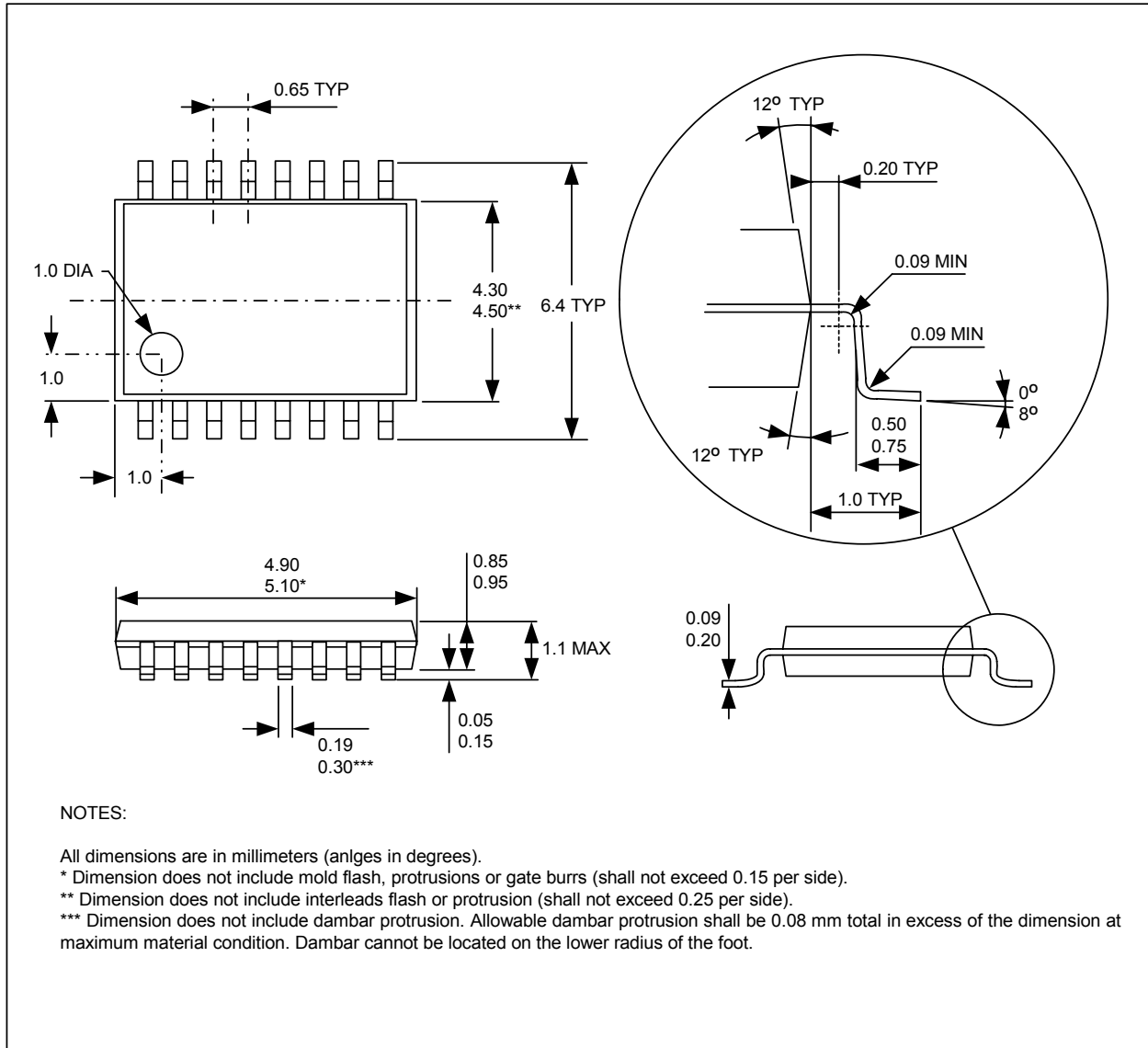

21. Disclaimer

Devices sold by Melexis are covered by the warranty and patent indemnification provisions appearing in its Term of Sale. Melexis makes no warranty, express, statutory, implied, or by description regarding the information set forth herein or regarding the freedom of the described devices from patent infringement. Melexis reserves the right to change specifications and prices at any time and without notice. Therefore, prior to designing this product into a system, it is necessary to check with Melexis for current information. This product is intended for use in normal commercial applications. Applications requiring extended temperature range, unusual environmental requirements, or high reliability applications, such as military, medical life-support or life-sustaining equipment are specifically not recommended without additional processing by Melexis for each application.

The information furnished by Melexis is believed to be correct and accurate. However, Melexis shall not be liable to recipient or any third party for any damages, including but not limited to personal injury, property damage, loss of profits, loss of use, interrupt of business or indirect, special incidental or consequential damages, of any kind, in connection with or arising out of the furnishing, performance or use of the technical data herein. No obligation or liability to recipient or any third party shall arise or flow out of Melexis' rendering of technical or other services.

© 2008 Melexis N.V. All rights reserved.

For the latest version of this document, go to our website at
www.melexis.com

Or for additional information contact Melexis Direct:

Europe, Africa, Asia:
Phone: +32 1367 0495
E-mail: sales_europe@melexis.com

America:
Phone: +1 603 223 2362
E-mail: sales_usa@melexis.com

ISO/TS 16949 and ISO14001 Certified